

General hints:

A. Intended age range

This equipment is suitable for children from 6 years.

B. Surfacing requirements

This equipment should be installed on an impact absorbing surfacing / loose fill material that accords with EN 1177 and is adequate for a maximum free height of fall of 1.00 m. We recommend lawn.

C. Foundations

Please see detailed instructions at the end of this document.

Special information:

Tested by TÜV Product Service GmbH.

Please do not alter any parts of the equipment or the construction itself since this may affect the safety standards and your guarantee.

We reserve the right to make technical alterations! For further information please call your local agent.

**Small Pyramid Tower
Order no. 3.41000**

Overall height 7 m

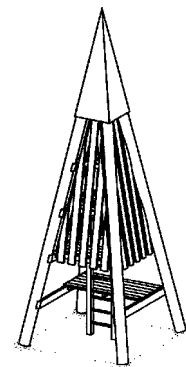

Data for shipment:

Number of parts: 16

- 4 posts
- 3 floor panels, one part
- 4 panellings
- 1 bundle tie beams (marking Z)
- 1 bundle floor beams (marking BZ)
- 1 ladder
- 1 top
- 1 bag of bolts

Total weight: 2500 kg

En-EN 01.06.2003

Copyright © Richter Spielgeräte GmbH * 83112 Frasdorf * Germany

Required space including safety distances (EN 1176):

485 x 415 cm

Ground elevation

Scale 1:50

all dimensions in cm

Foundation blocks

4 pieces 100 x 100 x 80 cm

Excavation depth 100 cm

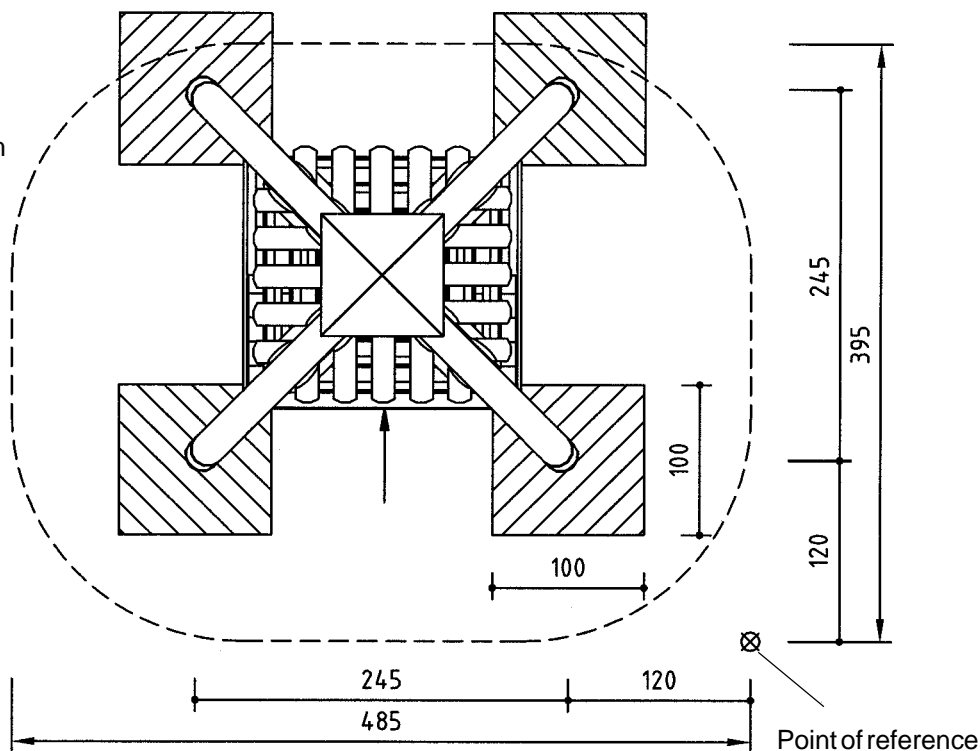

Point of reference

Recommended assembly aids:

- Set of carpenter's tools
- Set of ratchets
- Levelling instrument
- Rubber mallet
- Crane

Attention!

During the assembly period (including the setting of the concrete) it is not allowed to play on or put any weight on the equipment in order to secure stability during use after the assembly. Standard concrete requires at least 2 weeks to set.

Sequence of assembly operations:

1. Locate the site and take into account the space required, including the safety distances, according to the ground elevation on page 1.
2. Start surveying at the point of reference  and dig out the foundation holes and level.

3. Step 1 for construction of foundations:

Cast the foundation plates (concrete B 25, earth damp, largest grain size 16 mm, approx 15 to 20 cm thick) with horizontal wire mesh in the plate, and vertical wire mesh protruding from the plate according to the sketch.

Attention! All four foundation plates must be levelled to exactly the same elevation with respect to each other.

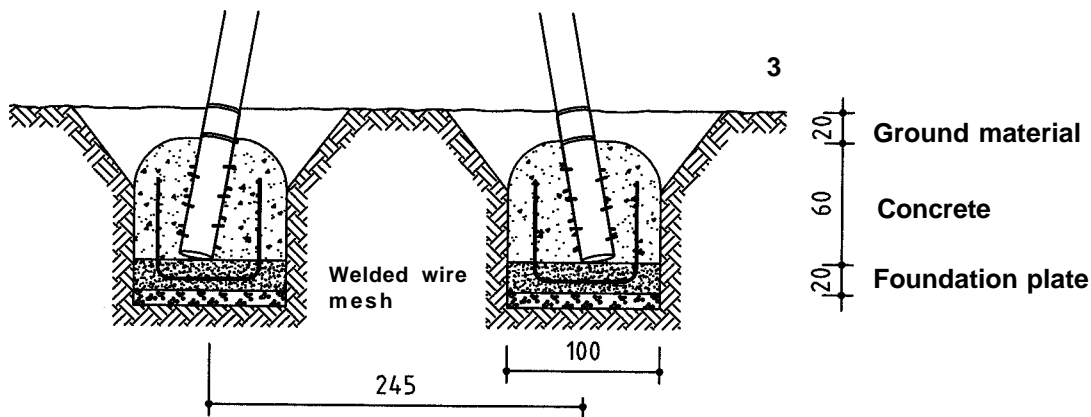

4. Arrange the posts 1 and 2, as well as 3 and 4 to form triangles and screw together loosely using threaded rods M 20.

5. Hammer the foundation irons into the posts.

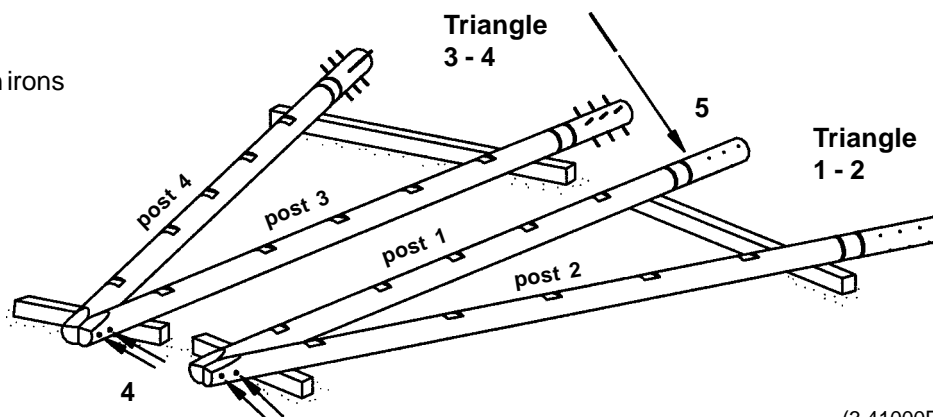

6. Working on triangle 1 - 2 screw on the tie beams **Z 6 - Z 10** and on triangle 3 - 4 the tie beams **Z 1 - Z 5** according to the markings. Finally tighten the threaded rods mentioned in point 4.

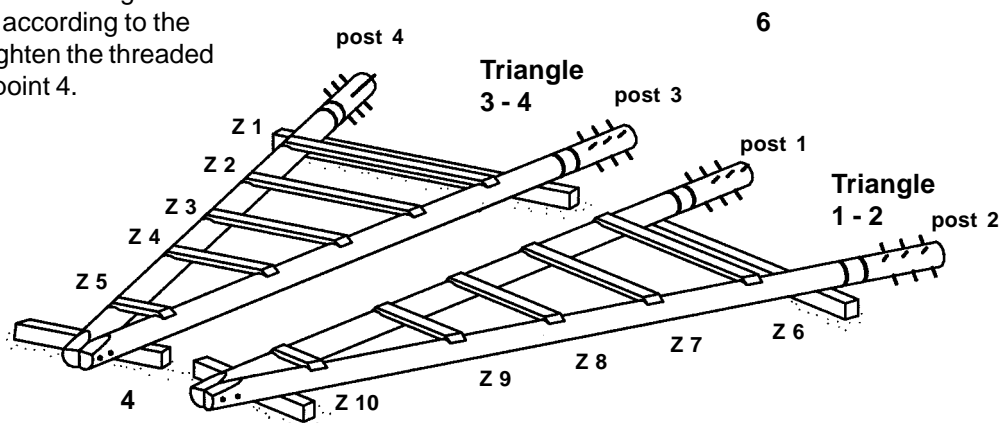

7. Tilt the triangles up in a vertical position (**posts 1 and 3 on the ground, tie beams facing inside**) and screw together using the threaded rods M 24 to form a pyramid. The angle between the posts is determined by the **floor 1, which is screwed onto the tie beams Z 1 and Z 6 (pay attention to the markings on the tie beams).**

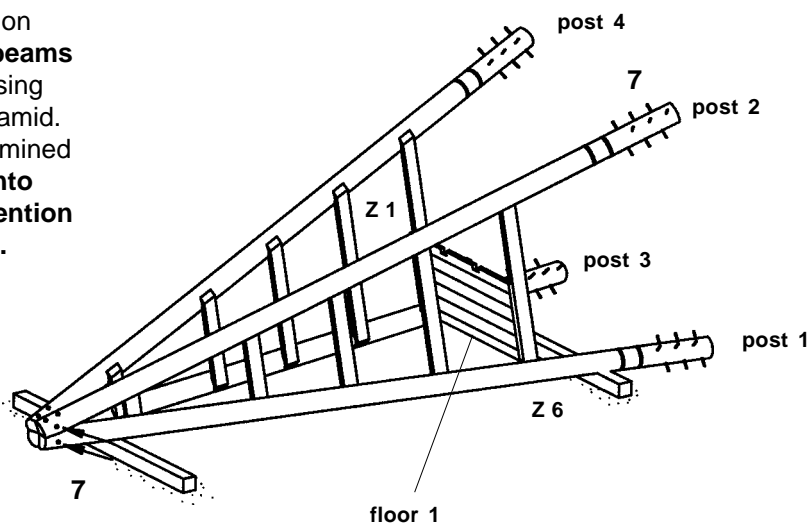

8. Screw together following the sequence below:

- a. floor 3 (pay attention to the markings)
- b. ladder
- c. floor 2 (pay attention to the markings)
- d. floor beams **BZ 1 - 6** (screwed onto the tie beams)

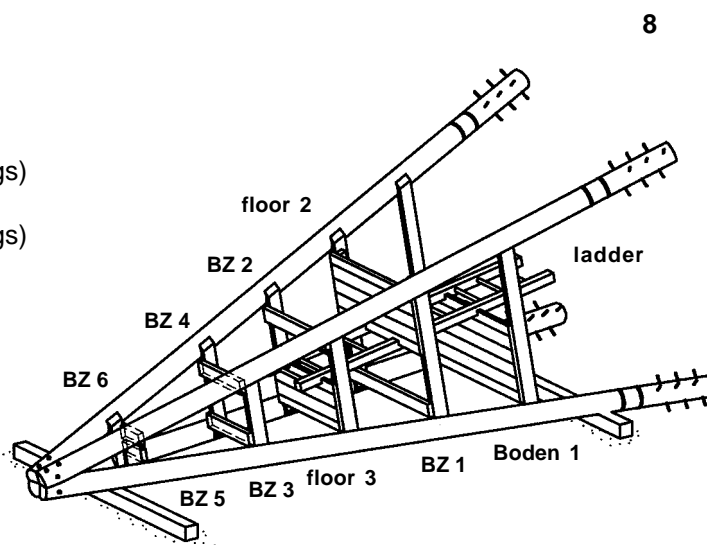

9. Install the panellings, start at the top of the pyramid.

10. Turn the pyramid around, using a crane, in order to finish the last side.

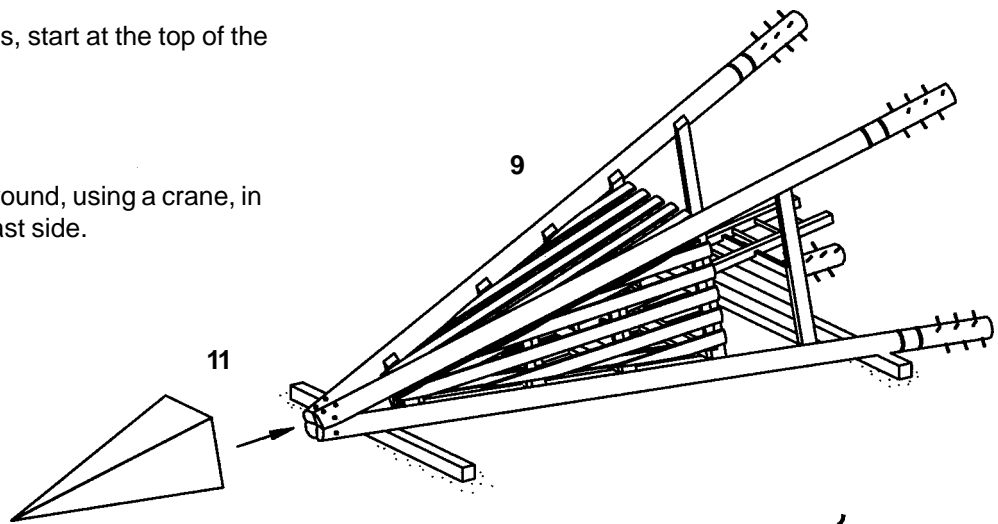

11. Install the top, hoist up the pyramid using a crane and place into the foundation holes.

12. Step 2 for construction of foundations:

Fill the foundation holes with concrete B 25 (earth damp), largest grain size 16 mm and tamp. Round the edges of the foundations and cover with ground material.

13. Repair minor damages caused during assembly or transportation.

14. Please ensure that all assembly aids, e. g. excess bolts, assembly instructions, distance battens or tape are removed entirely from the play equipment and the playground after work is finished.

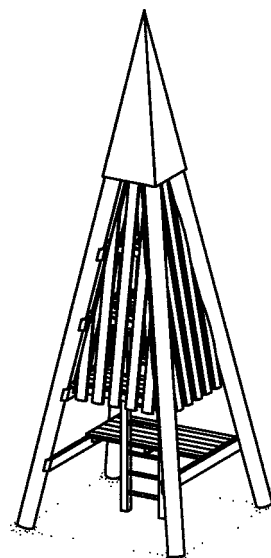
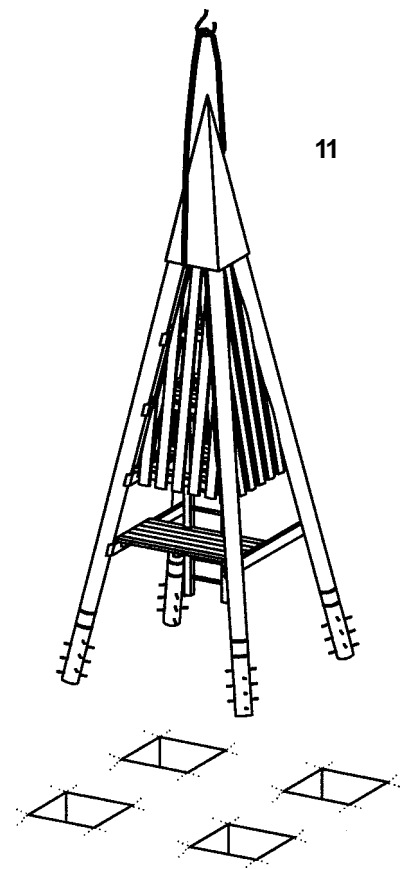

Please note that after about 6 weeks all screws and bolts need to be checked and, if necessary, retightened.