

General hints:

A. Surfacing requirements

This equipment should be installed on an impact absorbing surfacing / loose fill material that accords with EN 1177 and is adequate for a maximum free height of fall of 0.85 m.

B. Foundations

Please see detailed instructions at the end of this document, especially depths of foundations for steel feet.

Special information:

Tested by TÜV Product Service GmbH.

Please do not alter any parts of the equipment or the construction itself since this may affect the safety standards and your guarantee.

We reserve the right to make technical alterations!
For further information please call your local agent.

Tractor
Order no. 4.24000

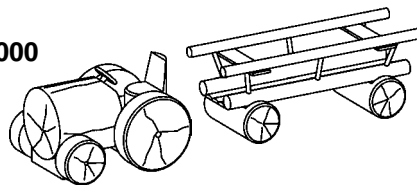

Trailer
Order no. 4.24010

Data for shipment:

Number of parts: 2

- 1 Tractor
- 1 Trailer
- each with 1 foundation iron

Total weight: 350 kg
Heaviest single part: 190 kg

En-EN 04.12.2006

Copyright © Richter Spielgeräte GmbH * 83112 Frasdorf * Germany

Required space including safety distances (EN 1176):

700 x 380 cm

Ground elevation

Scale 1:50

all dimensions in cm

Foundation blocks

Quality of concrete C 25/30

4 pieces 30 x 30 x 30 cm

Excavation depth 50 cm

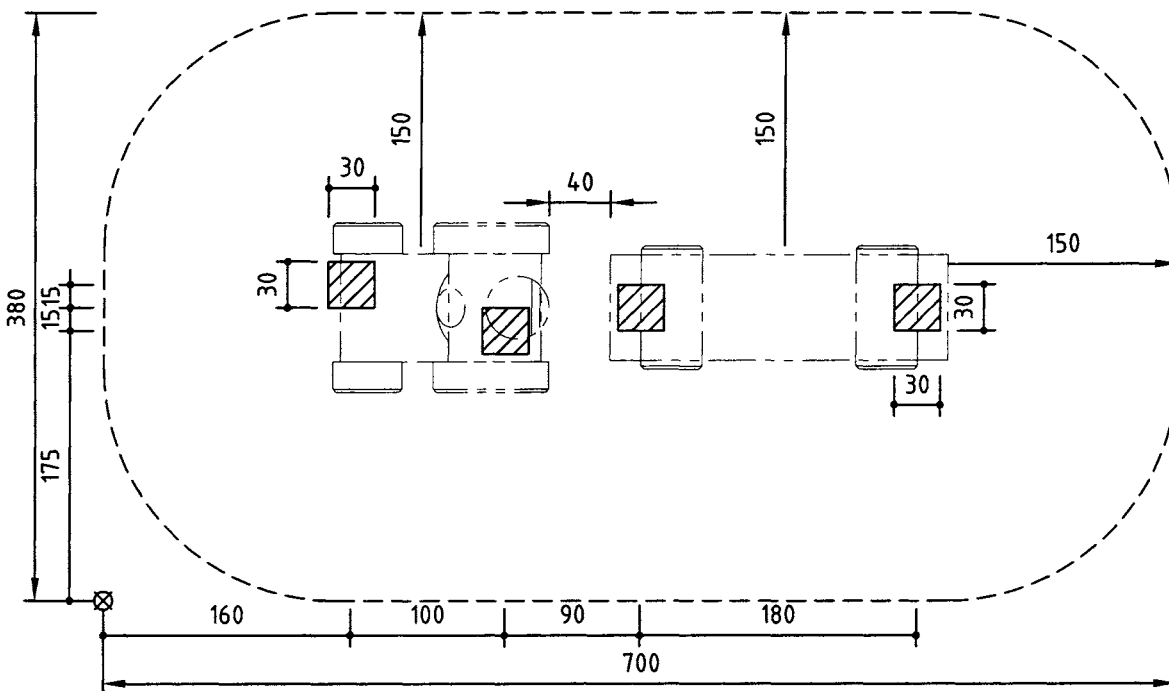

Recommended assembly aids:

Set of carpenter's tools

Attention!

During the assembly period (including the setting of the concrete) it is not allowed to play on or put any weight on the equipment in order to secure stability during use after the assembly. Standard concrete requires at least 2 weeks to set.

Sequence of assembly operations:

1. Locate the site and take into account the space required = fall space and operational space, according to the ground elevation on page 1.
2. Dig out the foundation holes.
3. Screw the foundation irons onto tractor and trailer.
4. Place both pieces into the foundation holes and align.

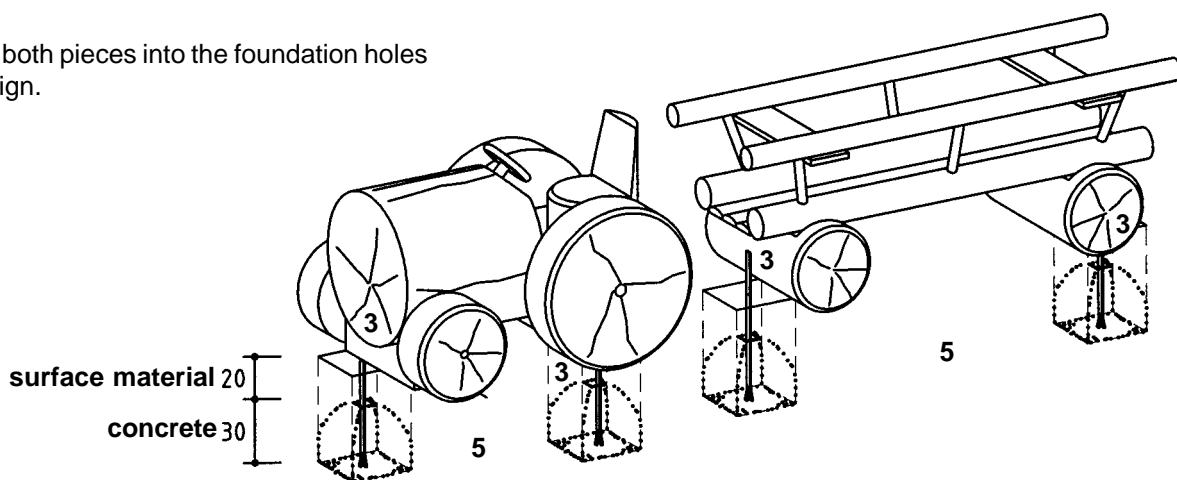

5. Fill the foundation holes with concrete (according to sketch), tamp and round the edges of the foundations.

**Please take into account the special sheet:
Notes on the construction of foundations.**

7. Repair minor damages caused during assembly or transportation.
8. Please ensure that all assembly aids, e. g. excess bolts, assembly instructions, distance battens or tape are removed entirely from the play equipment and the playground after work is finished.

