

General hints:

A. Surfacing requirements

This piece of equipment was not specifically designed as playground equipment but more as furniture, e.g. alternative seating and hence falls outside of the scope of EN 1176. Appropriate care should be taken, therefore, when planning for or placing this item on a playground.

B. Foundations

No foundations are required.

Special information:

Tested by TÜV Product Service GmbH.

Please do not alter any parts of the equipment or the construction itself since this may affect the safety standards and your guarantee.

We reserve the right to make technical alterations!
For further information please call your local agent.

Round table with 8 benches

Order no. 4.35000

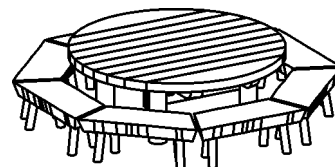

Data for shipment:

Number of parts: 10

- 1 round table top
- 1 bundle: Support frames
- 8 benches

Total weight: 650 kg

Largest single part: 230 kg

**Required space including safety distances (EN 1176):
Diameter 535 cm**

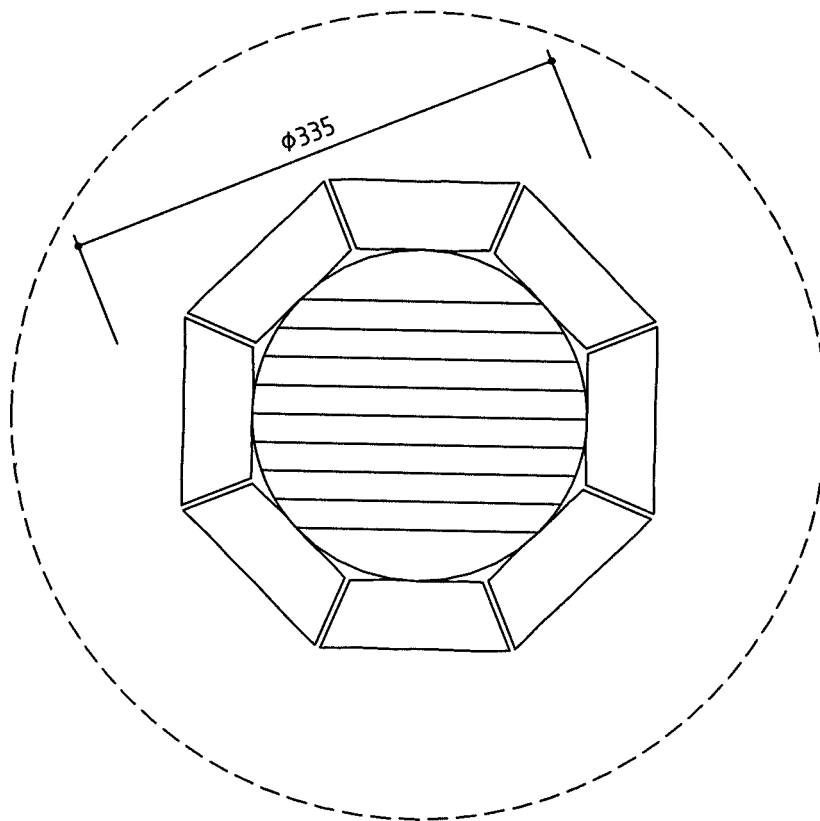

Ground elevation
Scale 1:50
all dimensions in cm

Recommended assembly tools:

Set of carpenter's tools
Rubber mallet

Sequence of assembly operations:

1. Locate the site and take into account the space required, including the safety distances, according to the ground elevation on page 1.
2. Screw the support frames to the tie beams.
3. Remove the transport battens from the underside of the table top.
4. Place the table top onto the support frame and screw onto the tie beams.

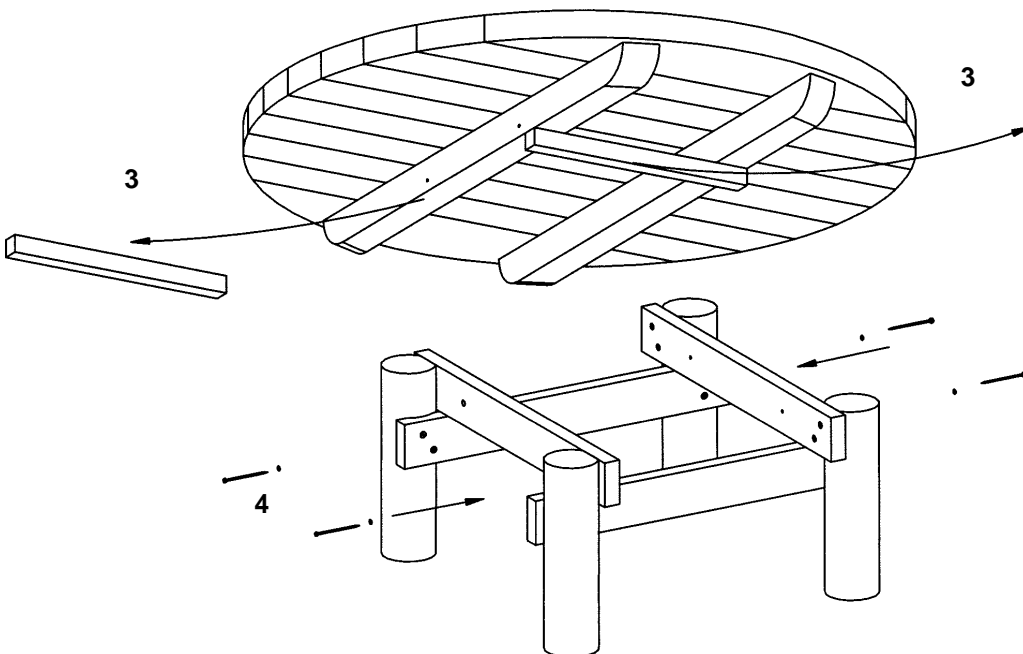
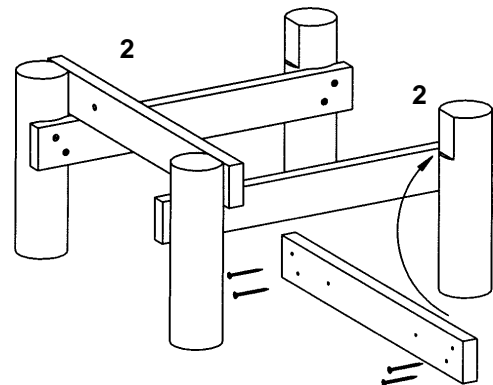

5. Arrange the benches around the table in a circle.
6. Repair minor damages caused during assembly or transportation.
7. Please ensure that all assembly aids, e. g. excess bolts, assembly instructions, distance battens or tape are removed entirely from the play equipment and the playground after work is finished.

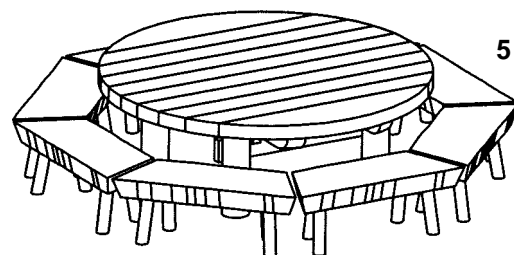

Please note that after about 6 weeks all screws and bolts need to be checked and, if necessary, retightened.