

General hints:

A. Intended age range

This equipment is suitable for children for all age groups

B. Surfacing requirements

This equipment does not reach the free height of fall limit of 600 mm above which a specific requirement for impact absorbing surfacing or materials is necessary.

C. Foundations

Please see detailed instructions at the end of this document.

Special information:

Tested by TÜV Product Service GmbH.

Please do not alter any parts of the equipment or the construction itself since this may affect the safety standards and your guarantee.

We reserve the right to make technical alterations!
For further information please call your local agent.

Sound Cushion
Order no. 9.02410



Data for shipment:

Number of parts: 1

1 sound cushion with 2 ground anchors

Total weight: 50 kg
Largest single part: 50 kg

En-EN 19.08.2002

Copyright © Richter Spielgeräte GmbH * 83112 Frasdorf * Germany

Required space including safety distances (EN 1176):

340 x 420 cm (example with 2 Sound Cushions)

Ground elevation

Scale 1:20

all dimensions in cm

Foundation blocks

2 pieces 20 x 60 x 30 cm

Excavation depth 50 cm

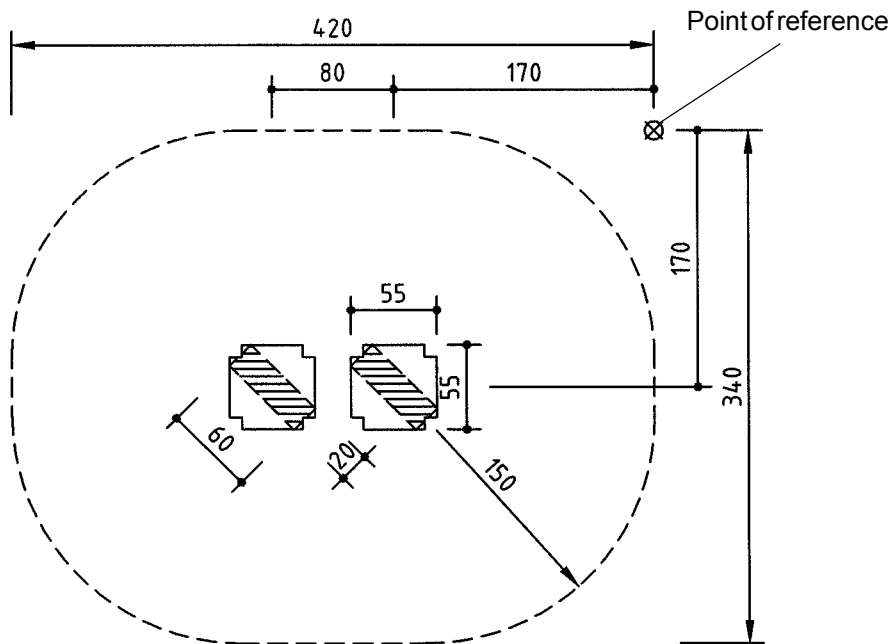

Recommended assembly aids:

- Set of carpenter's tools
- Set of ratchets

Sequence of assembly operations:

1. Locate the site and take into account the space required, including the safety distances, according to the ground elevation on page 1.

NOTE
Carefully choose the site in residential areas due to the sound created by the play equipment!

2. Start surveying at the point of reference .

3. Screw on the ground anchors.

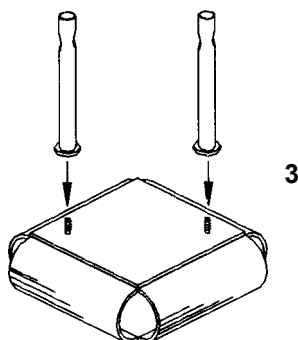

4. Place the Sound Cushions on the ground as desired and mark for the holes.

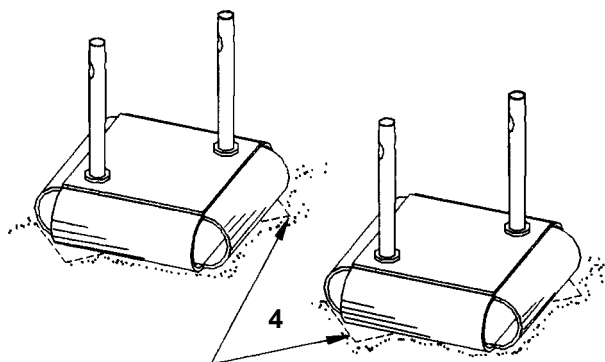

5. Depending on the number of Sound Cushions dig out the foundation holes and fill with concrete B 25 (to secure against moving), set the Sound Cushions and align. Top up the holes with ground material.

6. Repair minor damages caused during assembly or transportation.

7. Please ensure that all assembly aids, e. g. excess bolts, assembly instructions, distance battens or tape are removed entirely from the play equipment and the playground after work is finished.

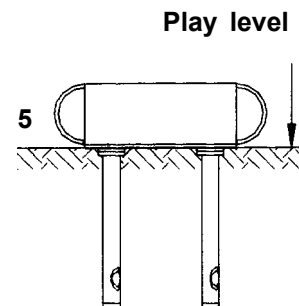
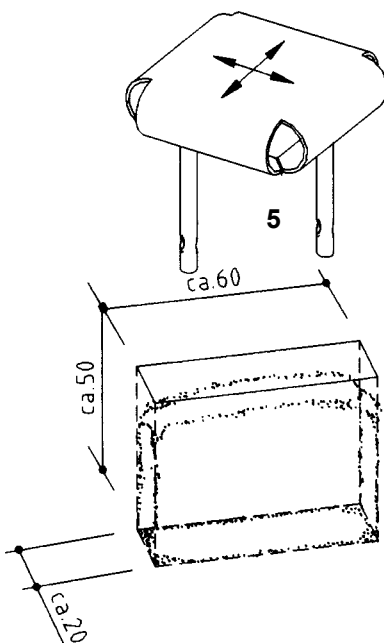

Please note that after about 6 weeks all screws and bolts need to be checked and, if necessary, retightened.