

**General hints:**

**A. Surfacing requirements**

This element does not reach the free height of fall limit of 600 mm above which a specific requirement for impact absorbing surfacing or materials is necessary.

**B. Foundations**

Please see detailed instructions at the end of this document, especially depths of foundations for steel feet.

**Special information:**

Tested by TÜV Product Service GmbH.

Please do not alter any parts of the equipment or the construction itself since this may affect the safety standards and your guarantee.

We reserve the right to make technical alterations!  
For further information please call your local agent.

**Kling Klang Disc**  
Order no. 9.08500

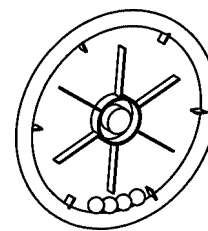

**Data for shipment:**

Number of parts: 1

1 complete equipment

Total weight: 100 kg

**Required space including operational space**  
Ø 150 cm

**Ground elevation**  
Scale 1:20  
all dimensions in cm

**Foundation block**  
Quality of concrete C 25/30

1 piece 50 x 50 x 60 cm  
Excavation depth 80 cm

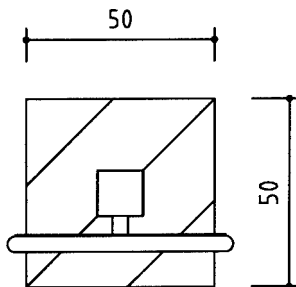

**Recommended assembly tools:**

- Set of carpenter's tools
- Set of ratchets
- Set of spanners
- Torx insert T 20, 25, 30, 40, 50
- Rubber mallet

**Attention!**

During the assembly period (including the setting of the concrete) it is not allowed to play on or put any weight on the equipment in order to secure stability during use after the assembly. Standard concrete requires at least 2 weeks to set.

**Sequence of assembly operations:**

1. Locate the site and take into account the space required, including the safety distances, according to the ground elevation on page 1.
2. Dig out the foundation hole.
3. Place the equipment into the foundation hole. Fill the foundation hole with concrete (according to sketch), tamp and round the edges. Cover the foundation with surfacing material up to ground level.

**Please pay attention to the additional sheet on the construction of foundations.**

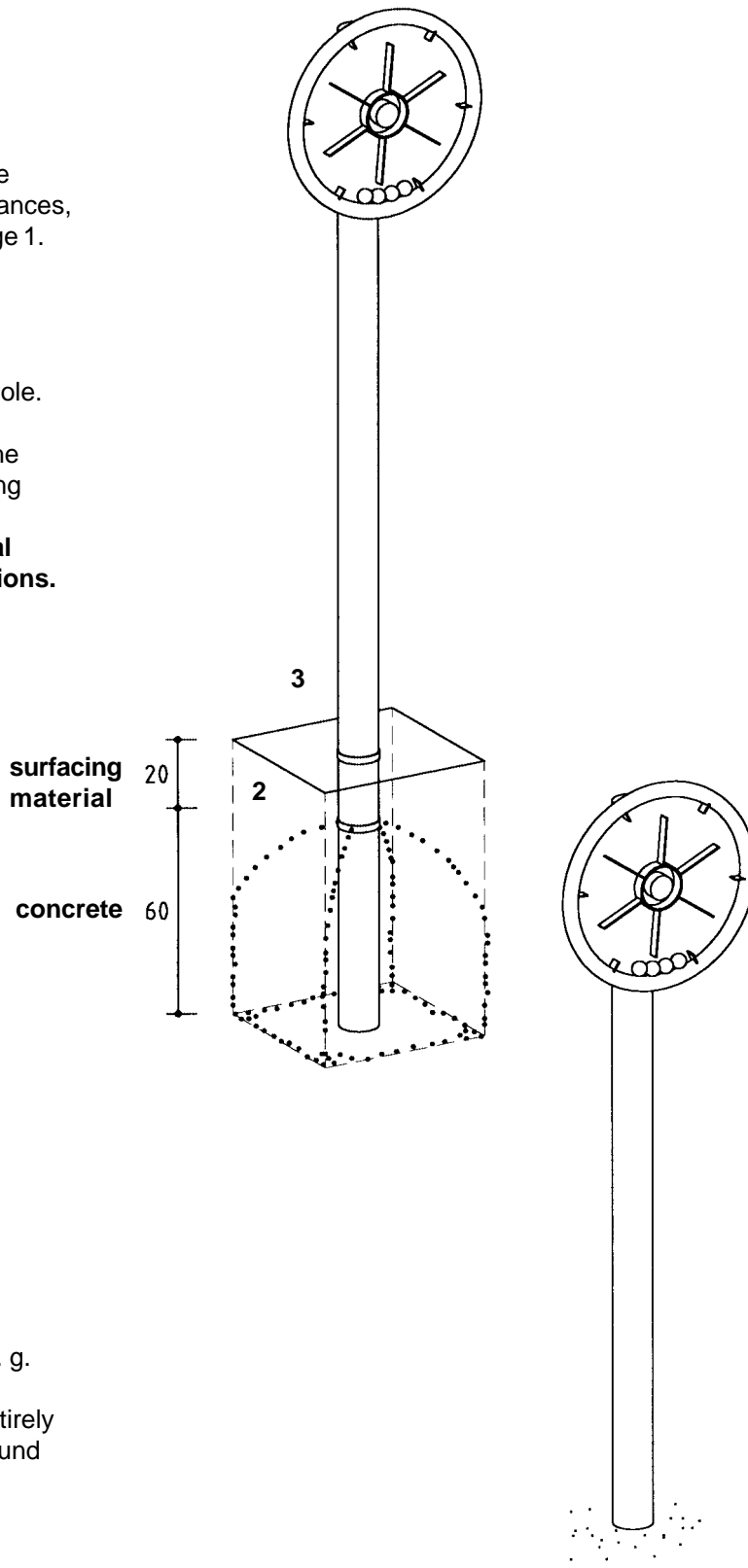

4. Repair minor damages caused during assembly or transportation.
5. Please ensure that all assembly aids, e. g. excess bolts, assembly instructions, distance battens or tape are removed entirely from the play equipment and the playground after work is finished.