

# Instructions for wear checks of play equipment

**Playground:** .....

**Date of installation:** .....

Checks depend on the kind of equipment. Any equipment with moving parts must be checked at least twice a year, static equipment at least once a year.

Intervals for maintenance work and checks generally depend on:

- location
- kind of use
- frequency of use
- possible vandalism

**For more details see also "General instructions for maintenance of playgrounds"**

**Snail Queen**  
**Order no. 4.24220**

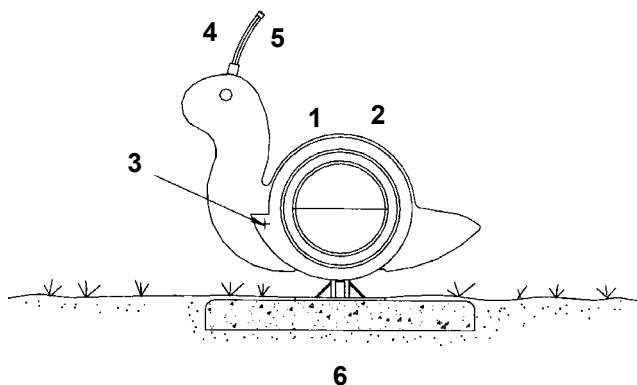

**The equipment must be checked for correct operation and safety, especially the points listed below:**

Proof of maintenance

1. 2. 3.

## Wooden parts

**1** Check for dry rot and smooth out splinters

**2** Check all the screw and bolt connections for firmness, tighten if necessary

## Rocking mechanism

**3** Check for smooth operation, check the action of the rubber shock absorber in the interior of the snail, if the snail's body doesn't stop smoothly renew the rubber shock absorber. Disassemble the snail's body on the marked side layer by layer and renew the rubber shock absorber

## Antenna

**4** Check the connection of the antenna for firmness

**5** Renew the antenna if the steel core is exposed

## Structural stability

**6** Check the anchoring of the Snail Queen to the ground

Special notes (e. g. for repairs): .....

Special notes (e. g. for repairs): .....

Special notes (e. g. for repairs): .....

**Repair not carried out, it is still possible to play on the equipment**

**Repair not carried out, equipment is taken out of action**

**All work carried out, everything is in order**

**Maintenance carried out by** .....

**Date** .....