

# Instructions for wear checks of play equipment

**Playground:** .....

**Date of assembly:** .....

Checks depend on kind of equipment. Any equipment with moving parts must be checked at least twice a year, static equipment at least once a year.

Intervals for maintenance work and checks generally depend on:

- location
- kind of use
- frequency of use
- possible vandalism

**For more details see also "General instructions for maintenance of playgrounds"**

**Cable way with big arch, 30 m  
Order no. 6.01110**

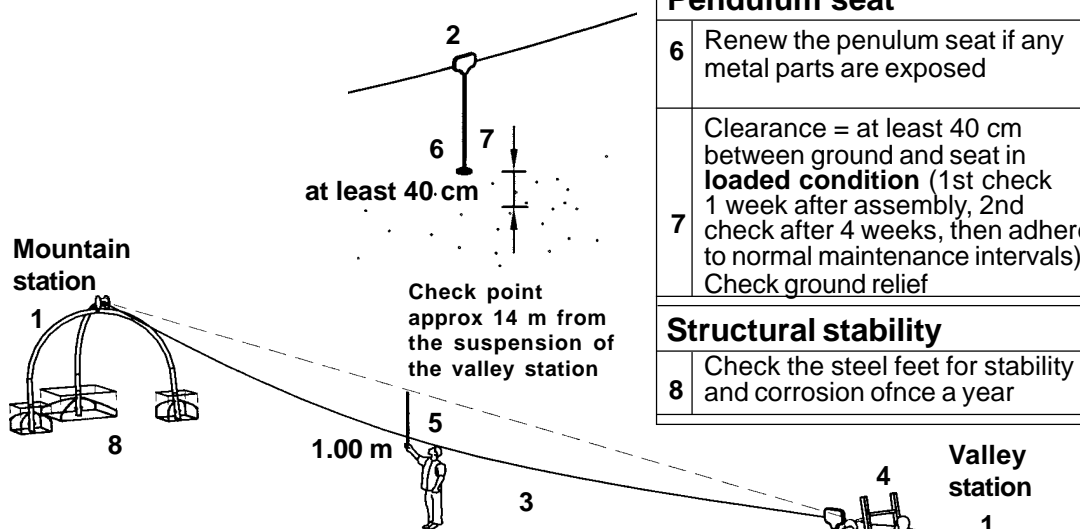

### Retightening of carrying cable:

Use pipe  $\varnothing$  20 mm, approx 50 cm long as lever, remove the safety screws. Tighten the cable in unloaded condition until the slack measures 1.00 m at the check point. Tighten the safety screws. The cable must be turned around the roller at least twice.

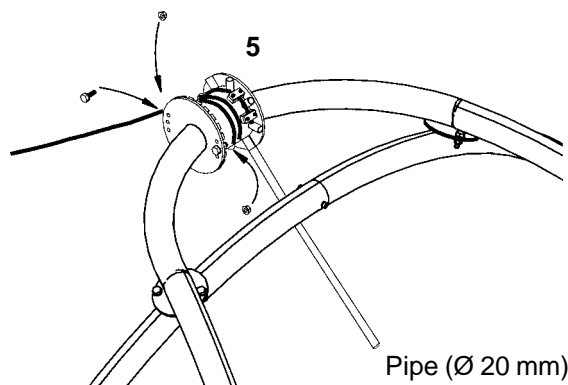

**The equipment must be checked for correct operation and safety, especially the points listed below:**

Proof of maintenance

1. 2. 3.

### Bolt connections

1 Check for firmness, if necessary tighten the screws

### Travelling crab

2 Check the travelling crab for smooth motion and/or damage

### Carrying cable and joints

3 Check the cable for damage, renew if necessary

4 Check universal cable joint (mountain station) for wear

5 Check the slack of the cable in **unloaded condition**. Measure the distance between the line of view between mountain and valley stations and the cable with the assistance of a second person at the check point. Distance = 1.00 m, see also the sketch opposite

### Pendulum seat

6 Renew the penulum seat if any metal parts are exposed

7 Clearance = at least 40 cm between ground and seat in **loaded condition** (1st check 1 week after assembly, 2nd check after 4 weeks, then adhere to normal maintenance intervals) Check ground relief

### Structural stability

8 Check the steel feet for stability and corrosion of once a year

Special notes (e. g. for repairs):  
Special notes (e. g. for repairs):  
Special notes (e. g. for repairs):

Repair not carried out, it is still possible to play on the equipment

Repair not carried out, equipment is taken out of action

All work carried out, everthing is in order

Maintenance carried out by .....

Date .....