

# Instructions for wear checks of play equipment

**Playground:** .....

**Date of installation:** .....

Checks depend on the kind of equipment. Any equipment with moving parts must be checked at least twice a year, static equipment at least once a year.

Intervals for maintenance work and checks generally depend on:

- location
- kind of use
- frequency of use
- possible vandalism

For more details see also "General instructions for maintenance of playgrounds"

## Climbing Wall

Order no. 7.77010

Example with 2 elements

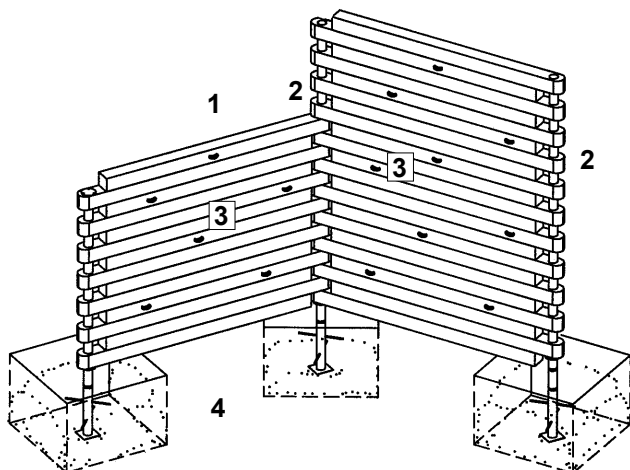

The equipment must be checked for correct operation and safety, especially the points listed below:

Proof of maintenance

### Wooden parts

**1** Check for dry rot and smooth out splinters

|                          |                          |                          |
|--------------------------|--------------------------|--------------------------|
| <input type="checkbox"/> | <input type="checkbox"/> | <input type="checkbox"/> |
|--------------------------|--------------------------|--------------------------|

**2** Check all screw and bolt connections for firmness; tighten if necessary

|                          |                          |                          |
|--------------------------|--------------------------|--------------------------|
| <input type="checkbox"/> | <input type="checkbox"/> | <input type="checkbox"/> |
|--------------------------|--------------------------|--------------------------|

### Climbing holds

**3** Check for wear and firmness, renew if necessary

|                          |                          |                          |
|--------------------------|--------------------------|--------------------------|
| <input type="checkbox"/> | <input type="checkbox"/> | <input type="checkbox"/> |
|--------------------------|--------------------------|--------------------------|

### Structural stability

**4** Dig out the foundations twice a year and check them for stability

|                          |                          |                          |
|--------------------------|--------------------------|--------------------------|
| <input type="checkbox"/> | <input type="checkbox"/> | <input type="checkbox"/> |
|--------------------------|--------------------------|--------------------------|

Special notes (e. g. for repairs): .....

Special notes (e. g. for repairs): .....

Special notes (e. g. for repairs): .....

Repair not carried out, it is still possible to play on the equipment

|                          |                          |                          |
|--------------------------|--------------------------|--------------------------|
| <input type="checkbox"/> | <input type="checkbox"/> | <input type="checkbox"/> |
|--------------------------|--------------------------|--------------------------|

Repair not carried out, equipment is taken out of action

|                          |                          |                          |
|--------------------------|--------------------------|--------------------------|
| <input type="checkbox"/> | <input type="checkbox"/> | <input type="checkbox"/> |
|--------------------------|--------------------------|--------------------------|

All work carried out, everything is in order

|                          |                          |                          |
|--------------------------|--------------------------|--------------------------|
| <input type="checkbox"/> | <input type="checkbox"/> | <input type="checkbox"/> |
|--------------------------|--------------------------|--------------------------|

Maintenance carried out by .....

Date .....