

Growing Older

Mobility and sensory perception in old age

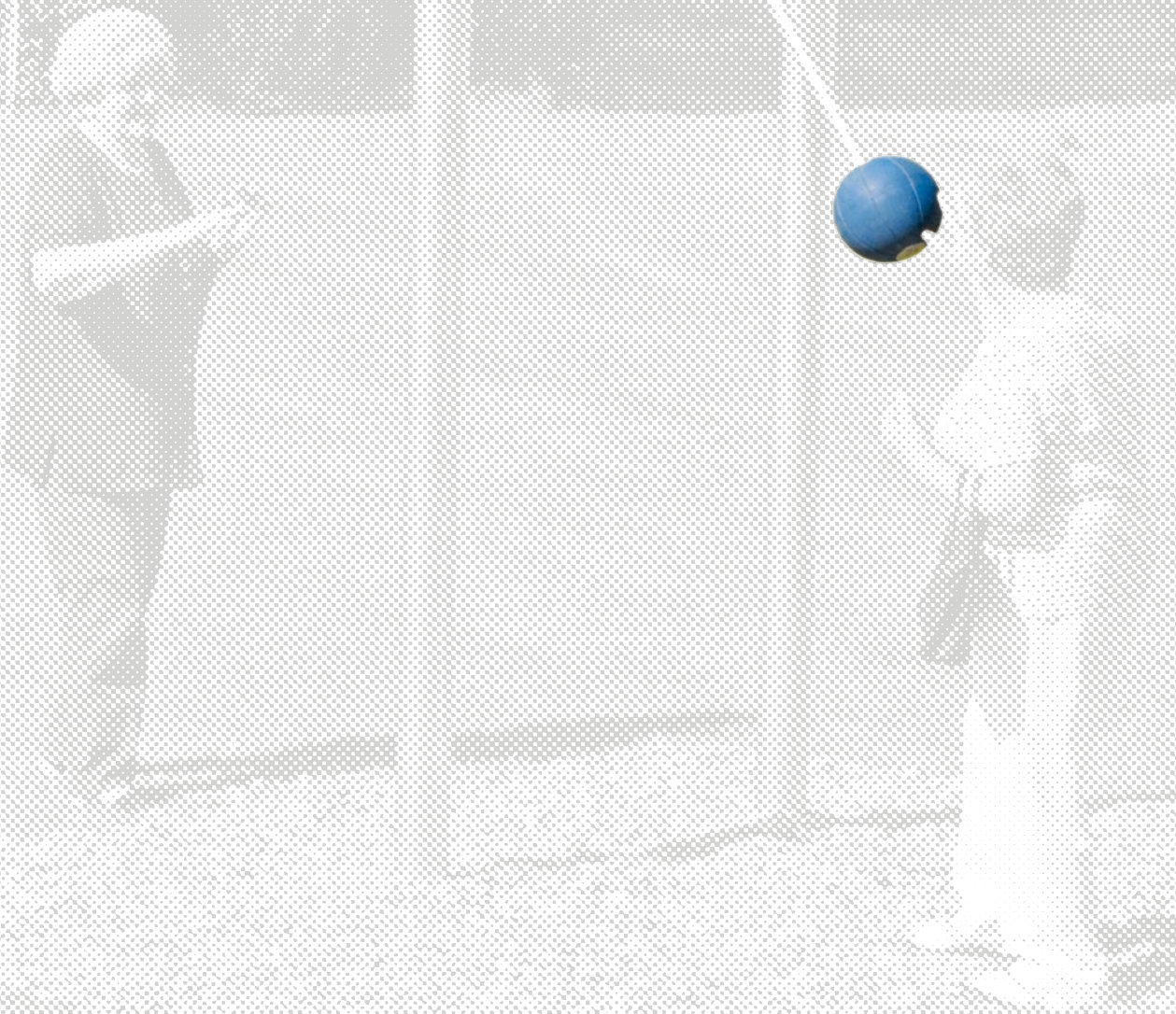

Richter Spielgeräte GmbH



Growing Older

is one of the most significant aspects of being human and affects us all.

Growing older is also accompanied by and characterised through different degrees and different rates of degeneration e.g.

- the senses no longer function as well as they used to
- cognition and memory diminishes
- it is not as easy to be spontaneous as it was in younger years
- the joints leave a lot to be desired.

People react in different ways to the effects of aging. It hits some hard and others less so. Whichever way: we are all responsible for helping to ensure that:

- this phase of life is characterised by a great deal of dignity and self-determination
- we make every effort, as far as possible, to preserve existing functionality as well as care for it.

With our little mobility program (physical and mental) we aim to offer older people a gentle opportunity to:

- exercise their joints and to relax their muscles but not in the sense of "getting fit" as our equipment shall not train the muscles rather than maintaining and improving the mental, emotional and physical mobility.
- appreciate the sensory perceptions that make life worth living
- be reminded of how we used to feel but also to still feel new experiences

It should be made clear that growing older can also mean gaining experience, discovering knowledge as well as learning that:

- aging does not just mean a loss
- it is helpful that any deficit be treated with understanding
- as far as is at all possible, a person stays active in a self-determined way

The equipment which we offer provides a "gentle" opportunity to experience this period of our life in a more enjoyable way. It would be wonderful if people could more often say:

"I like growing old."

Frasdorf, August 2018

Richter Spielgeräte GmbH
Simsseestraße 29
D-83 112 Frasdorf
Phone +49-80 52-1 79 80
Fax +49-80 52-41 80
www.richter-spielgeraete.de
info@richter-spielgeraete.de



Contents

Mobility equipment made of wood

Page	5	Curve Track
	7	Saw
	9	Step Bench
	11	Arm Game
	13	Marbles Table
	15	Bending Tree
	17	Weight Pillars

Mobility equipment made of stainless steel

	21	Turning Bow
	23	Turning Bar
	25	Turning Plate
	27	Turning Capstan
	29	Turning Seat
	31	Swinging Ball

Generationen-Aktiv-Park®

	34	Information about the term “cross-generation”
--	----	---

Concepts

	35	Basic Concept
	36	BasicPlus Concept
	37	Premium Concept
	38	Example of a course

Strengthening physical health

	39	Leg Press
	41	Rowing Machine
	43	Boxing Bike
	45	Stomach and Back Trainer

Improving agility and coordination

	47	Ball Game
	49	Kling Klang
	51	Street Car
	53	Balancing Path

Improving thought and memory performance

	55	Training the Mind, Information Board
--	----	--------------------------------------

Practicing everyday situations

	57 - 66	Life Path - 6 Stations
--	---------	------------------------

Play Stations for Developing the Sense

	69 - 72	According to Hugo Kükelhaus
	73 - 79	Play Stations

Mobility equipment made of wood

Promoting mobility and fun in exercise is the aim of the following equipment designed by Martin Linacisoro. It is for lifting and lowering, movement and strengthening of the shoulders and arms and lightly stretching the waist. But this equipment also is not without fun. Hence it becomes a meeting point for young and old. Explanation boards in unsupervised areas are recommended.





The illustrations show the sandwich construction which we use as the base for this equipment.

Function

The Curved Track improves manual agility. The up and down movement of pushing a paired handle along a specially designed track serves to simultaneously exercise the arms, shoulders and wrists. As well, every figure which is made by moving the handle is recognisable and is, likewise, integratable into the therapy.



Curve Track

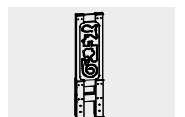

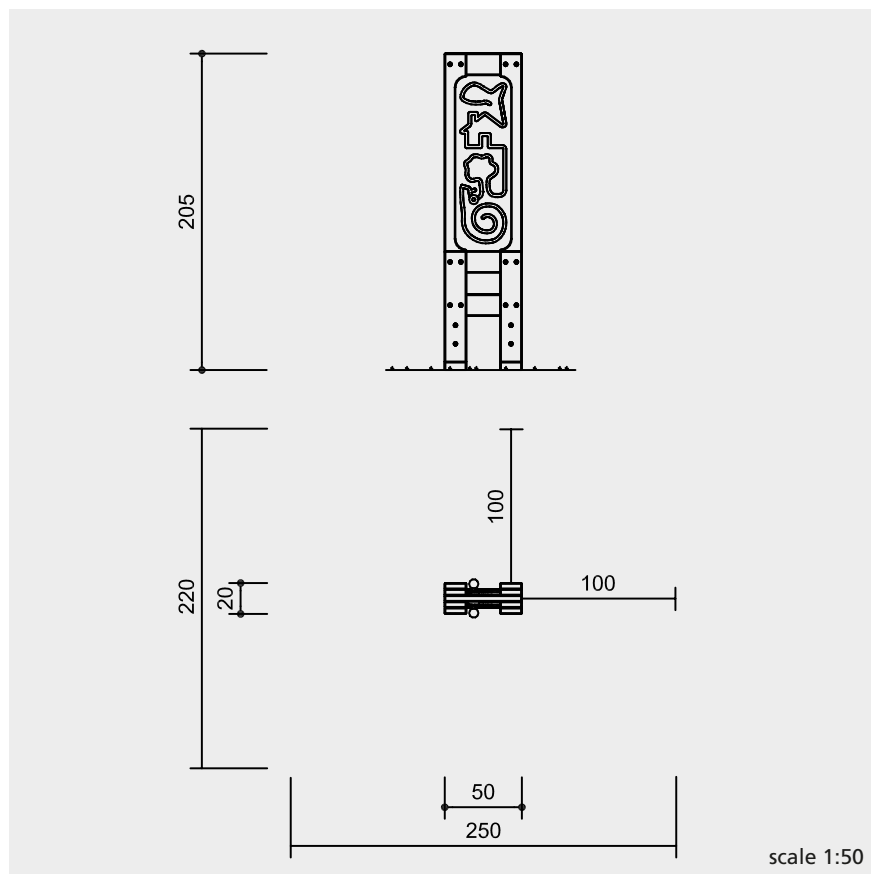

Technical information

Core-free timber

sawn-timbers of mountain larch, selected according to eight quality criteria, core-free thus decreasing the occurrence of cracking



Adjustable

no projecting threads after re-tightening due to two-piece bolt connection and therefore easy to maintain



Ground anchor

foundation anchor made of phenol resin paper based laminate



sandwich construction frame, oiled, non-positive fitting

curve track made of stainless steel (thickness 10 mm)

handle bar and balls made of polyamide

Dimensions

(small deviations possible)

height 2.05 m
width 0.50 m
depth 0.20 m
depth incl. handles 0.30 m

weight approx. 160 kg

Components

1 complete curve track including 4 foundation anchors

Installation information

Surfacing no requirements

Foundations
1 item 60 x 90 x 40 cm
excavation 60 cm

Attention!

Exact measurements may vary, for all installation dimensions refer to current installation instructions.
Subject to technical changes!

Safety

This equipment is not playground equipment within the scope of EN 1176 and therefore is also not subject to the requirements of this standard. Nevertheless, it is complied with where appropriate.

For more detailed explanation of the quality characteristics see price list.

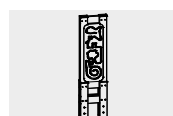

11.01100

Function

This is a piece of equipment with the typical push and pull movements of sawing. It promotes movement and strengthening of the arms and shoulders. It is possible to hold with one or both hands; furthermore sawing can be done individually or with a partner. Angling the saw up or down also allows it to be used in different positions.



Copyright © Richter Spielgeräte GmbH  07/14

Design M. Linacisoro

Saw



11.01200

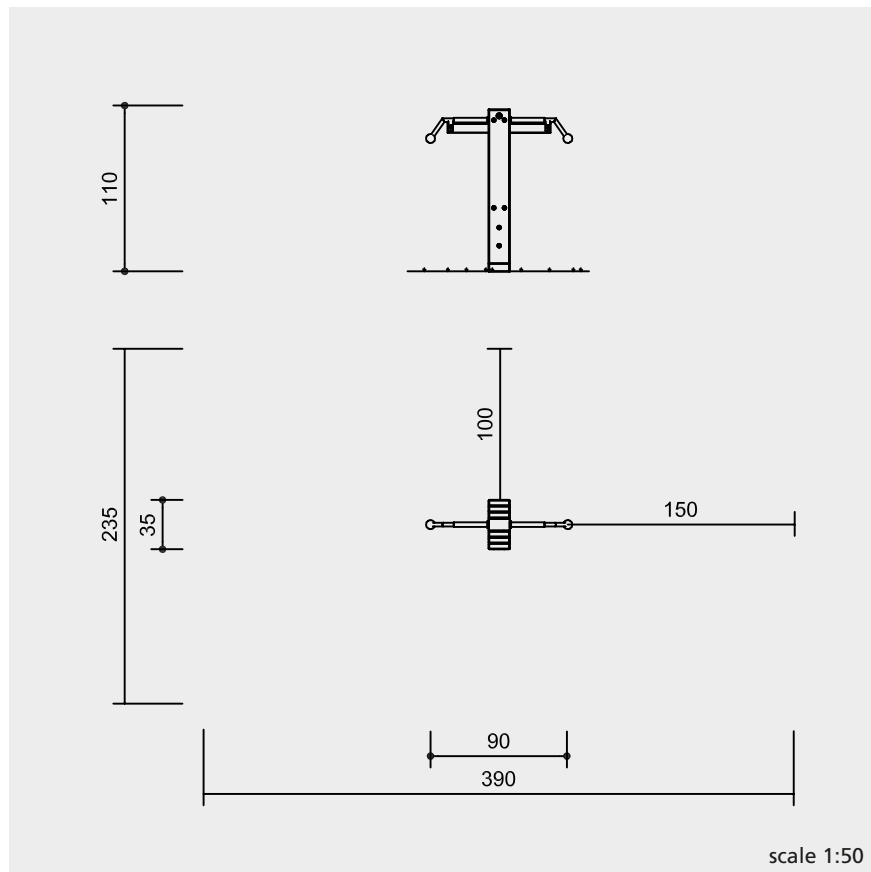

Technical information

Core-free timber

sawn-timbers of mountain larch, selected according to eight quality criteria, core-free thus decreasing the occurrence of cracking



Adjustable

no projecting threads after re-tightening due to two-piece bolt connection and therefore easy to maintain



Ground anchor

foundation anchor made of phenol resin paper based laminate



sandwich construction frame, oiled, non-positive fitting

saw made of stainless steel

handle balls made of polyamide

Dimensions

(small deviations possible)

height	1.10 m
width	0.90 m
depth	0.35 m
saw deflection	0.50 m max.

weight approx. 80 kg

For more detailed explanation of the quality characteristics see price list.

Components

1 complete saw
including 2 foundation anchors

Installation information

Surfacing
no requirements

Foundations
1 item 60 x 70 x 40 cm
excavation depth 60 cm

Attention!

Exact measurements may vary, for all installation dimensions refer to current installation instructions.

Subject to technical changes!

Safety

This equipment is not playground equipment within the scope of EN 1176 and therefore is also not subject to the requirements of this standard. Nevertheless, it is complied with where appropriate.



11.01200

Function

The Step Bench has three different heights for sitting, according to body size and desires. Moreover, alternatively standing and sitting at each predefined height is an exercise which strengthens the leg and back muscles. Ball handles are installed on the arm rests to help with standing up.



Copyright © Richter Spielgeräte GmbH 10/14

Design M. Linacisoro

Step Bench

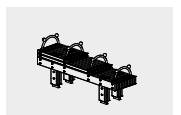

11.01300

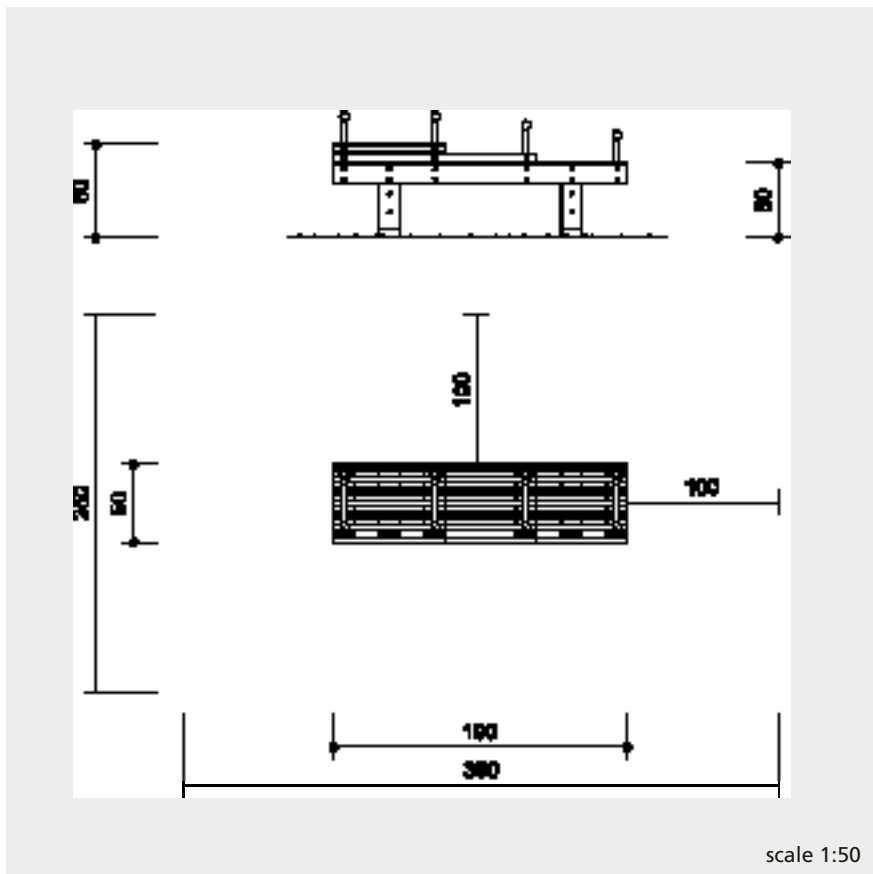

Technical information

Core-free timber

sawn-timbers of mountain larch, selected according to eight quality criteria, core-free thus decreasing the occurrence of cracking



Adjustable

no projecting threads after re-tightening due to two-piece bolt connection and therefore easy to maintain



Ground anchor

foundation anchor made of phenol resin paper based laminate



sandwich construction frame, oiled, non-positive fitting

arm rests made of stainless steel

handle balls made of polyamide

Dimensions

(small deviations possible)

height	0.60 m
height	
incl. arm rests	0.85 m
width	1.90 m
depth	0.50 m
weight approx.	180 kg

Components

1 step bench
with 4 foundation anchors

Installation information

Surfacing
no requirements

Foundations
2 items 60 x 80 x 40 cm
excavation depth 60 cm

Attention!

Exact measurements may vary, for all installation dimensions refer to current installation instructions.
Subject to technical changes!

Safety

This equipment is not playground equipment within the scope of EN 1176 and therefore is also not subject to the requirements of this standard. Nevertheless, it is complied with where appropriate.

For more detailed explanation of the quality characteristics see price list.

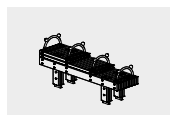

11.01300

Function

In the Arm Game the alternating forwards and backwards movement of the handles in their guides can be compared to the movements of the poles in cross-country skiing and in „Nordic Walking“, except that here it takes place on the same spot. Varying the pressure means the handles slide either easier or harder.



Copyright © Richter Spielgeräte GmbH  07/14

Design M. Linacisoro

Arm Game



11.01400

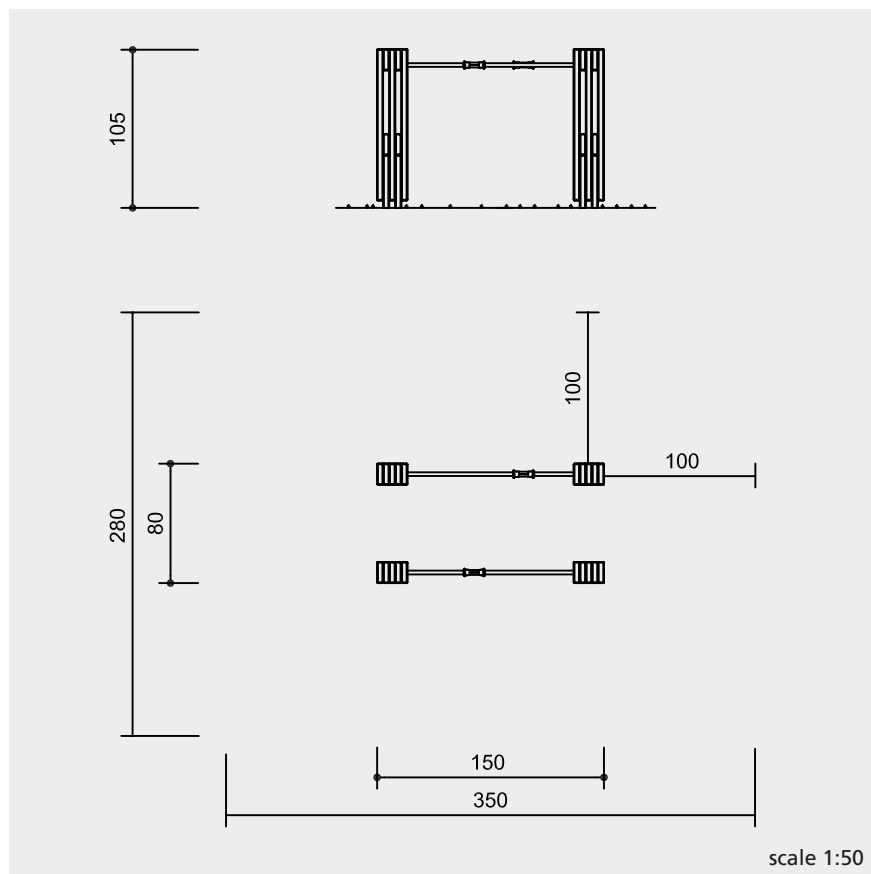

Technical information

Core-free timber

sawn-timbers of mountain larch, selected according to eight quality criteria, core-free thus decreasing the occurrence of cracking



Adjustable

no projecting threads after re-tightening due to two-piece bolt connection and therefore easy to maintain



Ground anchor

foundation anchor made of phenol resin paper based laminate



sandwich construction frame, oiled, non-positive fitting

handle bar made of stainless steel

handles made of polyamide

Dimensions

(small deviations possible)

height 1.05 m
width 1.50 m
depth 0.80 m

weight approx. 180 kg

For more detailed explanation of the quality characteristics see price list.

Components

- 4 support posts including foundation anchors
- 2 handle bars with handles

Installation information

Surfacing
no requirements

Foundations
2 items 60 x 120 x 40 cm
excavation 60 cm

Attention!

Exact measurements may vary, for all installation dimensions refer to current installation instructions.

Subject to technical changes!

Safety

This equipment is not playground equipment within the scope of EN 1176 and therefore is also not subject to the requirements of this standard. Nevertheless, it is complied with where appropriate.

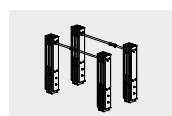

11.01400

Function

The Marbles Table can be compared to the popular "Mouse hunt". By moving the marbles table you can drop the marbles in the holes. Skill and coordination are called for, especially if this game is being played by several people.

Barrier-free

- independent play



Marbles Table



11.01500

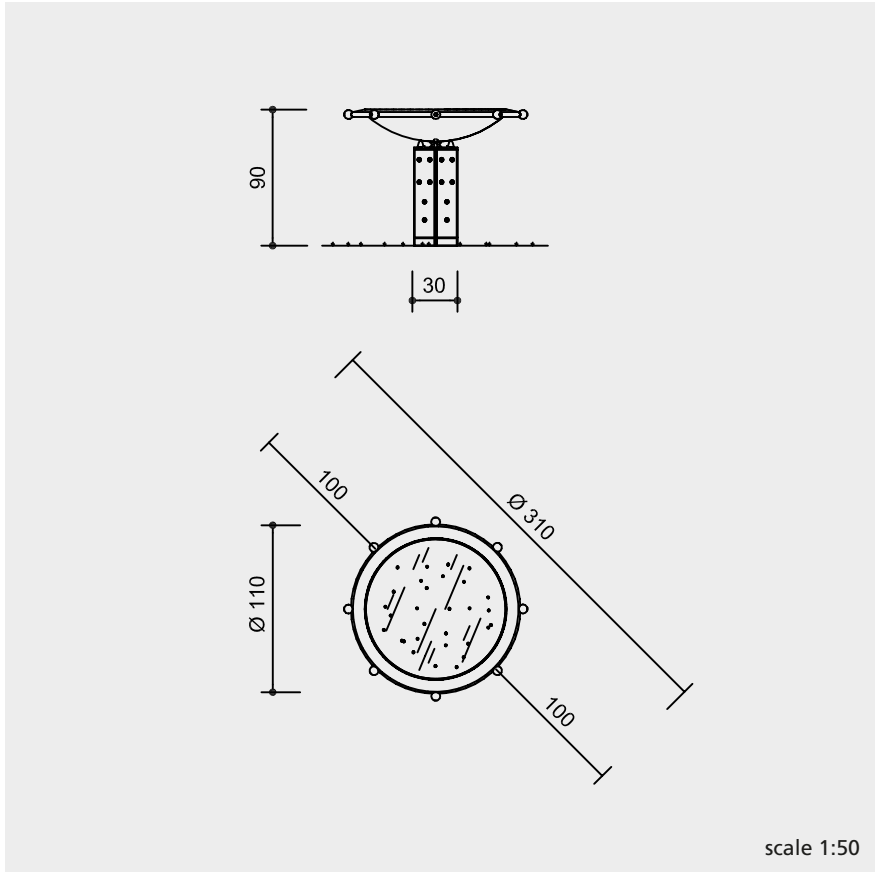

Safety check according to EN 1176

Components

- 1 marbles table
- 1 support post including
- 4 foundation anchors

Installation information

- Surfacing
- no requirements
- Foundations
- 1 item 60 x 70 x 40 cm
- excavation depth 60 cm

Attention:
Exact measurements may vary, for all installation dimensions refer to current installation instructions.
 Technical changes reserved.

Technical information

core-free timber
 sawn timbers of non-impregnated mountain larch, core-free, thus decreasing the occurrence of cracking



adjustable
 no projecting threads after re-tightening due to two-piece bolt connection and therefore easy to maintain



ground anchor
 guidance plate for marbles and foundation anchor made of phenol resin paper based laminate



sandwich construction frame, oiled, non-positive fitting

dish made of stainless steel, glass bead blasted

cover made of single-pane safety glass, 10 mm

marbles Ø 25 mm made of POM (18 pieces)

support made of rubber buffers for controlled rocking movement

handle balls made of polyamide

Dimensions

(small deviations possible)

height	0.90 m
diameter	1.10 m
weight	180 kg

For more detailed explanation of the quality characteristics see price list.



11.01500



Function

The Bending Tree promotes the movement of the waist and hips. Walking around it requires that you simultaneously bend down to different heights.



Bending Tree

Copyright © Richter Spielgeräte GmbH  07/14

Design M. Linacisoro



11.01600

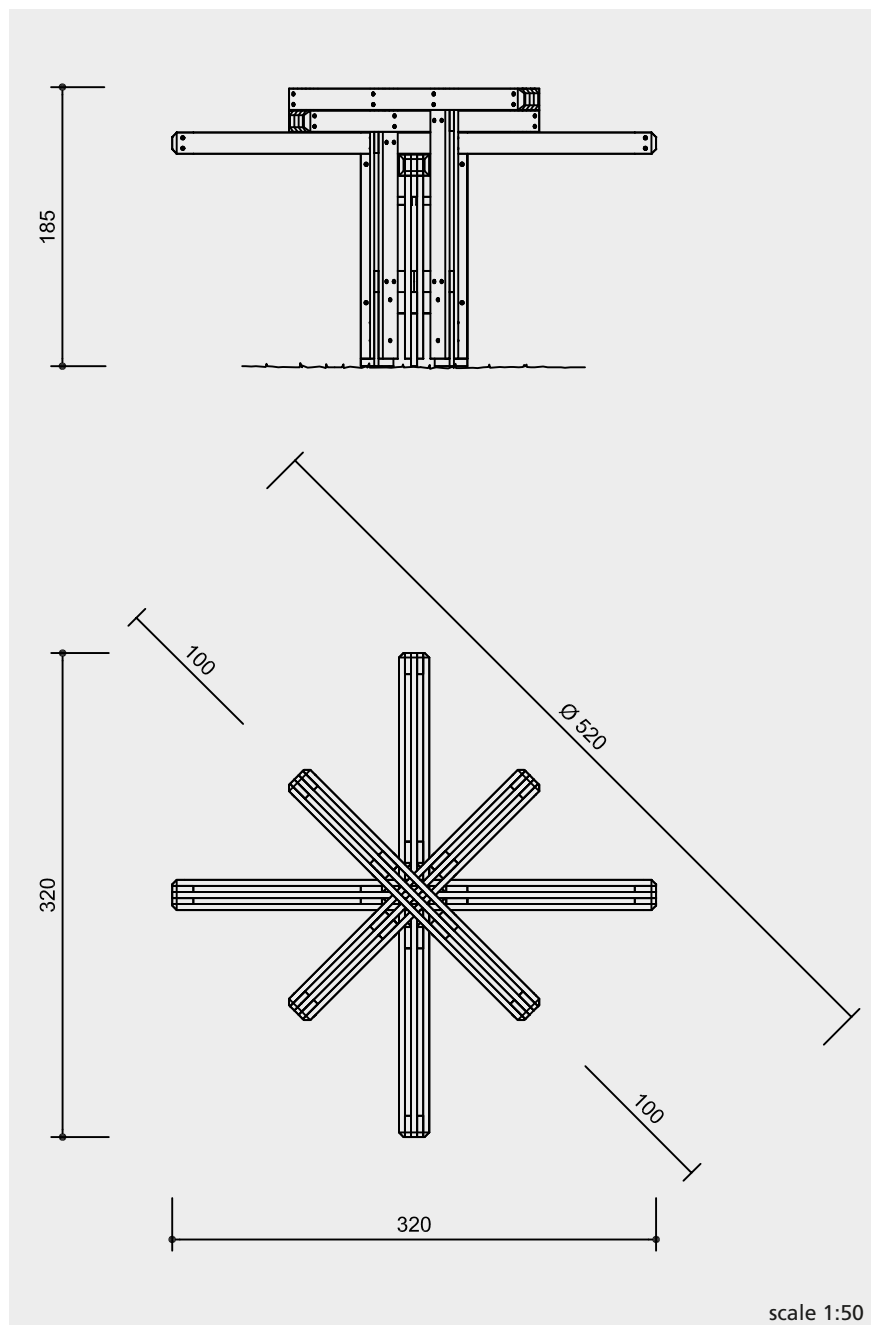

Technical information

Core-free timber

sawn-timbers of mountain larch, selected according to eight quality criteria, core-free thus decreasing the occurrence of cracking



Adjustable

no projecting threads after re-tightening due to two-piece bolt connection and therefore easy to maintain



Ground anchor

foundation anchor made of phenol resin paper based laminate



sandwich construction frame, oiled, non-positive fitting

Dimensions

(small deviations possible)

height 1.85 m
width 3.20 m
depth 3.20 m

weight approx. 380 kg

Safety

This equipment is not playground equipment within the scope of EN 1176 and therefore is also not subject to the requirements of this standard. Nevertheless, it is complied with where appropriate.

For more detailed explanation of the quality characteristics see price list.

Components

1 middle section
including 8 foundation anchors
4 beams

Installation information

Surfacing
no requirements

Foundations
1 item 120 x 120 x 40 cm
excavation 60 cm

Attention!

Exact measurements may vary, for all installation dimensions refer to current installation instructions.

Subject to technical changes!



11.01600

Function

The Weight Pillar is a column for lifting and lowering weight bars at different heights. It supports the movement and strength of the arms, wrists and shoulders. The weight bar can be locked into place at differing heights.



Weight Pillar

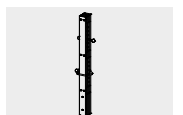

11.01700

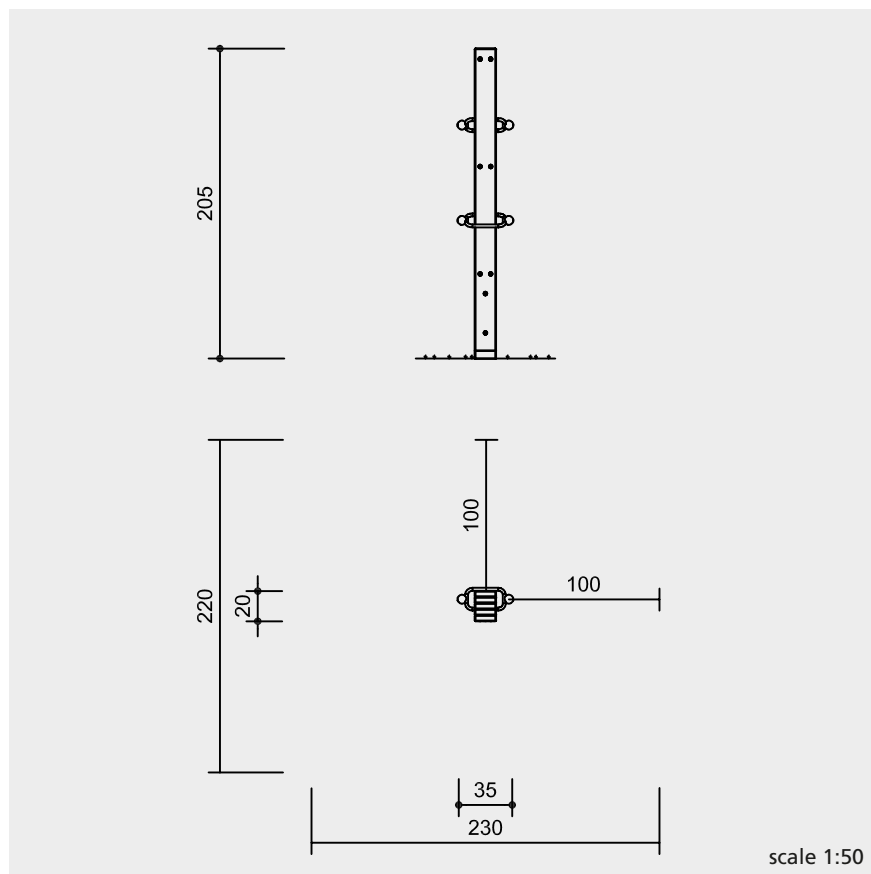

Technical information

Core-free timber

sawn-timbers of mountain larch, selected according to eight quality criteria, core-free thus decreasing the occurrence of cracking



Adjustable

no projecting threads after re-tightening due to two-piece bolt connection and therefore easy to maintain



Ground anchor

foundation anchor made of phenol resin paper based laminate



sandwich construction frame, oiled, non-positive fitting

handles made of stainless steel

handle balls made of polyamide

Dimensions

(small deviations possible)

height	2.05 m
width	0.20 m
depth	0.14 m
depth incl. bars	0.35 m

weight approx. 80 kg

For more detailed explanation of the quality characteristics see price list.

Components

1 complete weight pillar equipment including 2 foundation anchors

Installation information

Surfacing
no requirements

Foundations
1 item 60 x 60 x 40 cm
excavation 60 cm

Attention!

Exact measurements may vary, for all installation dimensions refer to current installation instructions.

Subject to technical changes!

Safety

This equipment is not playground equipment within the scope of EN 1176 and therefore is also not subject to the requirements of this standard. Nevertheless, it is complied with where appropriate.

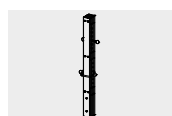

11.01700



Mobility equipment made

of stainless steel

We would also like to foster movement and enjoyment in movement with the following mobility course by Sergi Fernández Herrera.

This equipment is especially designed for the requirements of older people. The lighter exercise program is mainly for stability and agility when walking or standing, for gripping and for arm movements.

Explanation boards in unsupervised areas are recommended.

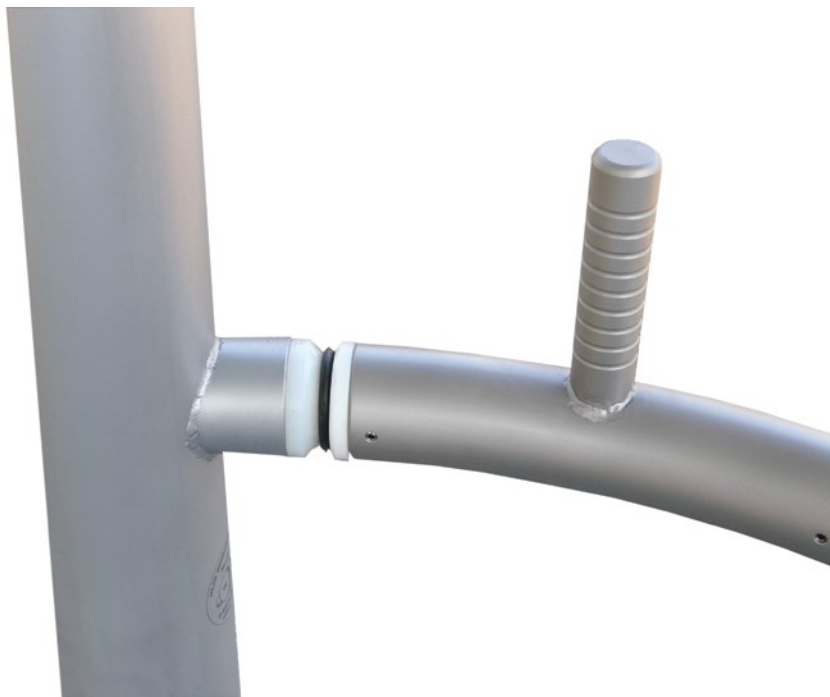
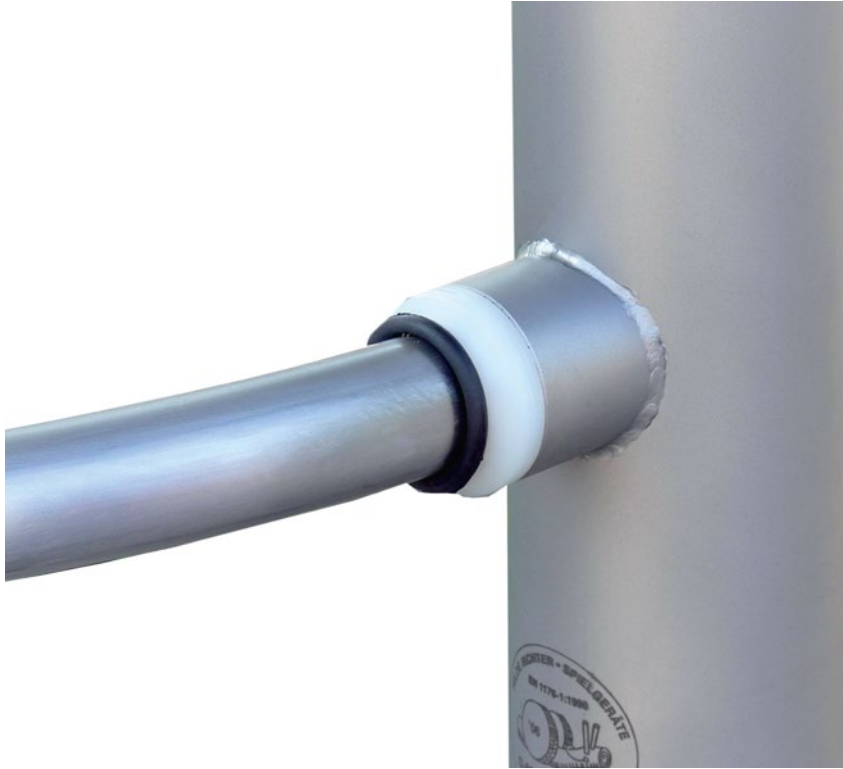

The illustrations show the workmanship and construction with the chosen materials.

Function

The Turning Bow provides stimulation for the arms as well as rotating movements for the hips and shoulders. You tightly hold the handles with two hands and push the moving part of the equipment from left to right and back and then vice versa. Using the equipment involves no risks and enables gentle physical activity.



Turning Bow

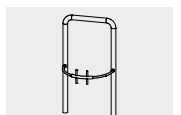

11.02100

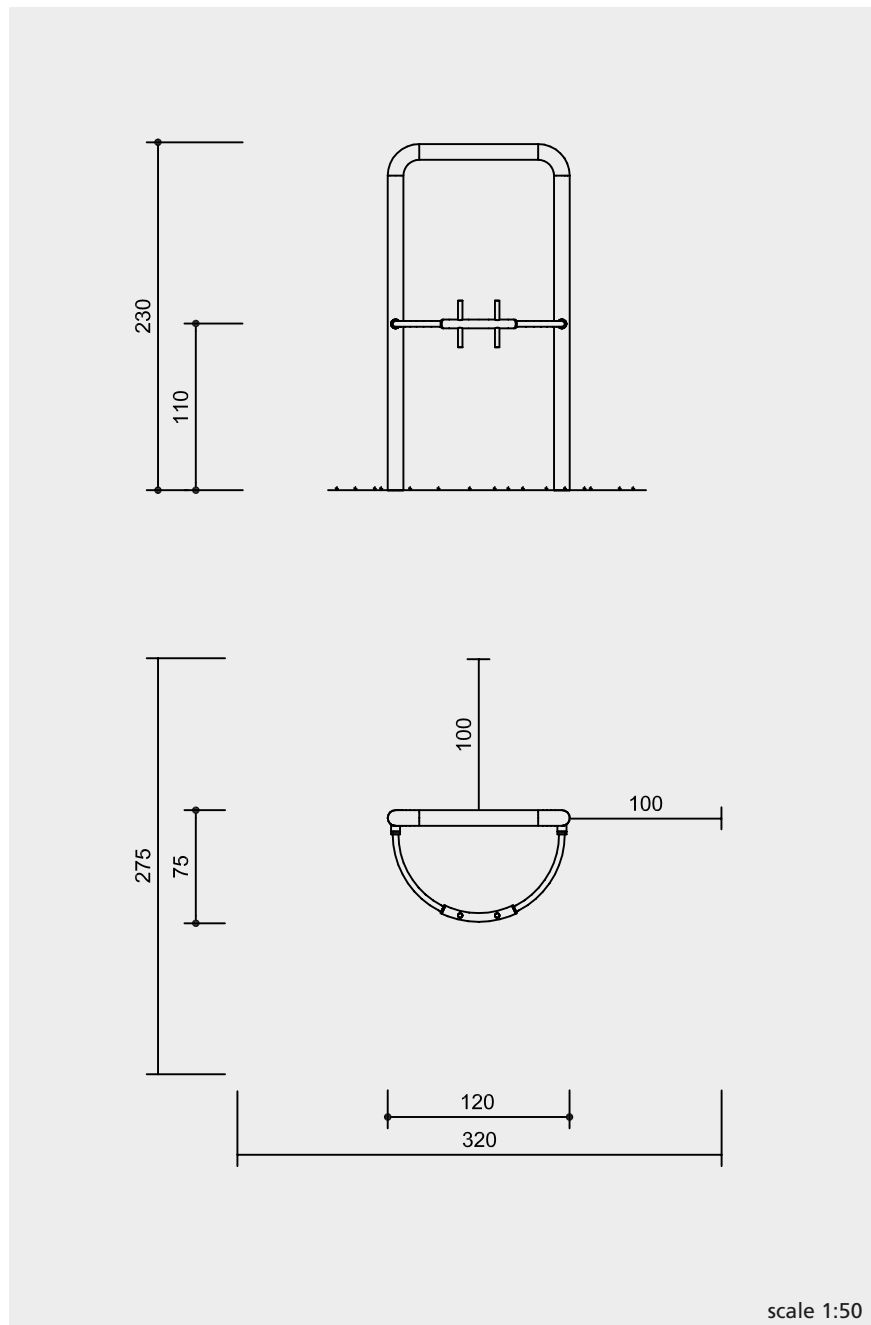

Technical information

equipment made of stainless steel

tube diameter 104 mm

handles made of polyoxymethylene (POM-C), standard colour blue

turning bow mounted in sleeve bearings made of plastic

Dimensions

(small deviations possible)

total height	2.30 m
height of turning bow	1.10 m
width	1.20 m
depth	0.75 m
weight	50 kg

Safety

This equipment is not playground equipment within the scope of EN 1176 and therefore is also not subject to the requirements of this standard. Nevertheless, it is complied with where appropriate.

Components

1 completely assembled piece of equipment

Installation information

Surfacing
no requirements

Foundations
2 items 50 x 50 x 40 cm
excavation depth 60 cm

Attention!
Exact measurements may vary, for all installation dimensions refer to current installation instructions.
Subject to technical changes!

Equipment also available in bolt-on version.

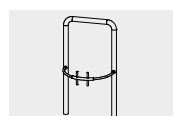

11.02100

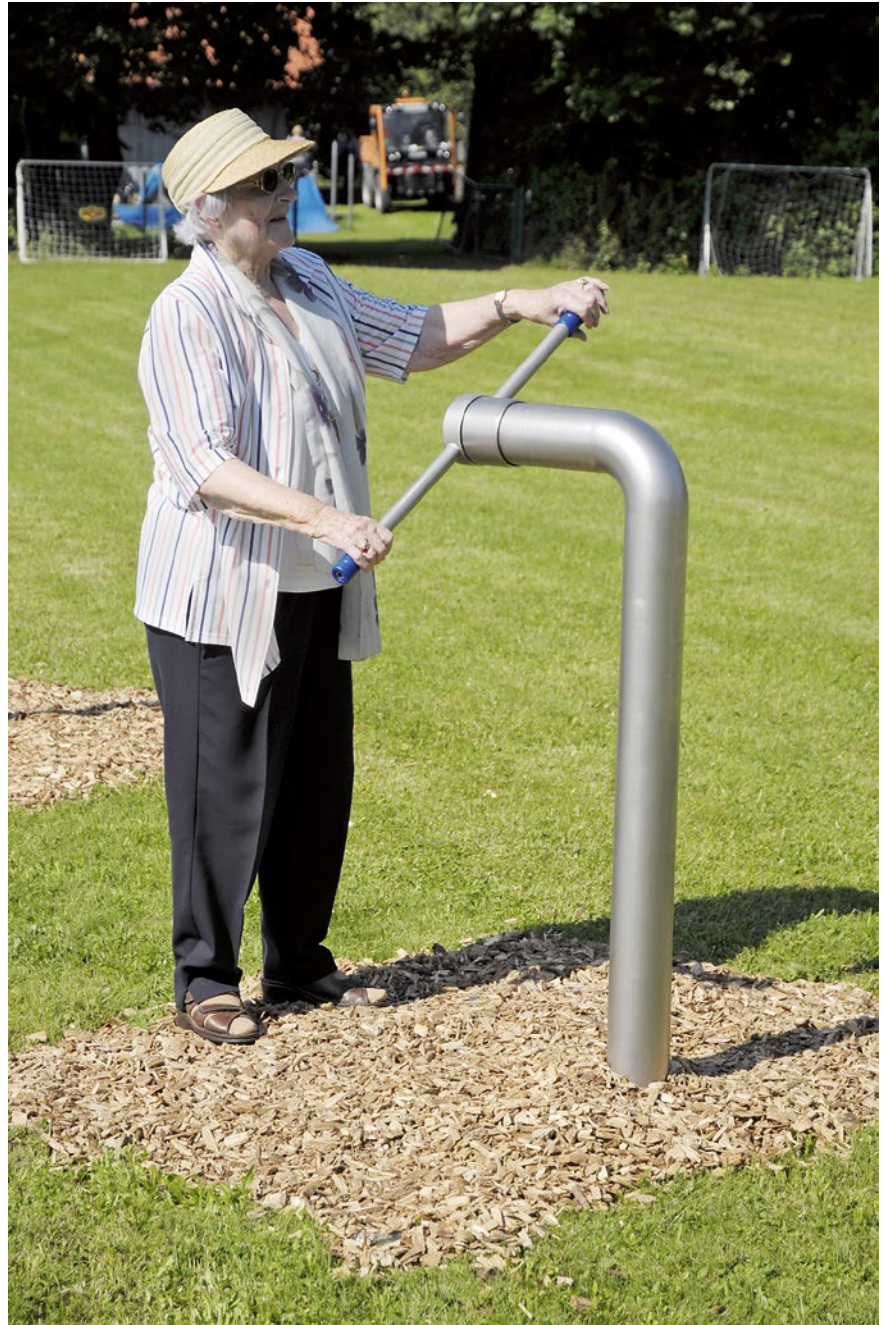

Function

The Turning Bar supports movement of the arms and wrists. With this exercise common movements are improved. You tightly hold the turning bar with both hands and move it in both directions.



Turning Bar

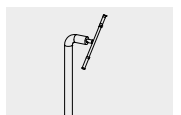

11.02200

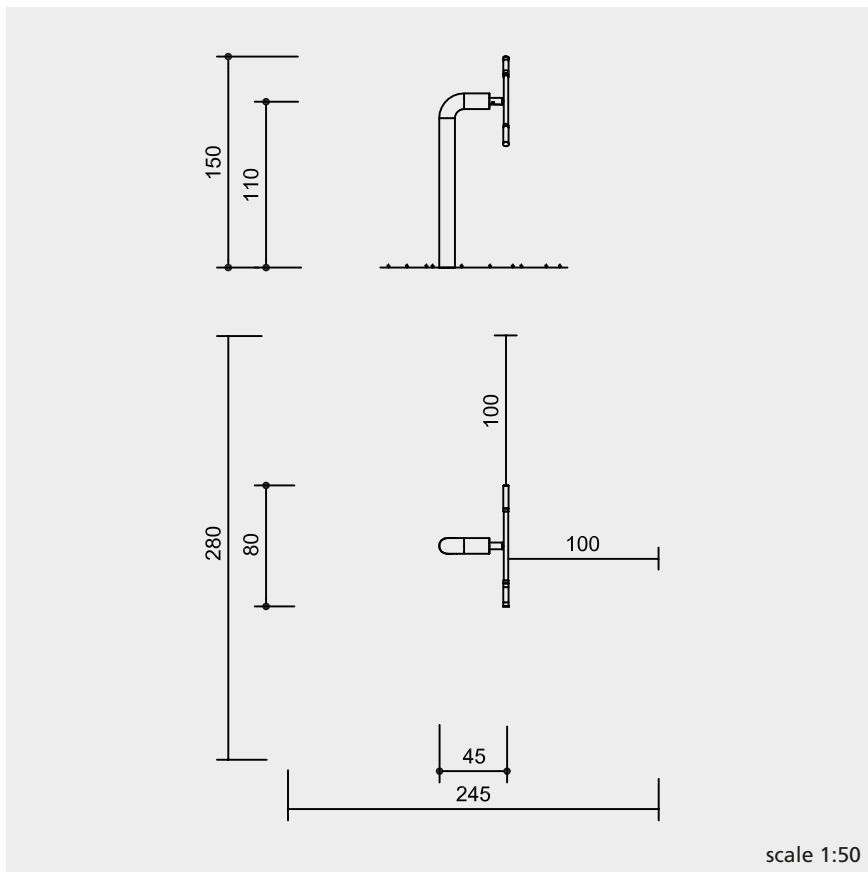

Technical information

equipment made of stainless steel

tube diameter 104 mm

turning bar mounted in sleeve bearings
made of plastic

handles made of polyoxymethylene
(POM-C), standard colour blue

Dimensions

(small deviations possible)

height 1.50 m

width 0.80 m

depth 0.45 m

weight approx. 32 kg

Safety

This equipment is not playground equipment within the scope of EN 1176 and therefore is also not subject to the requirements of this standard. Nevertheless, it is complied with where appropriate.

Components

1 completely assembled piece of equipment

Installation information

Surfacing
no requirements

Foundations
1 item 50 x 50 x 40 cm
excavation 60 cm

Attention!

Exact measurements may vary, for all installation dimensions refer to current installation instructions.
Subject to technical changes!

Equipment also available in bolt-on version.



11.02200



Function

The Turning Plate is a piece of equipment which stimulates the horizontal mobility of the shoulders and elbows. This exercise can be very beneficial for those people who have lost mobility and who lack stability and strength in their motion sequences.



Turning Plate

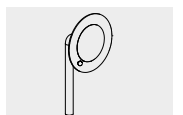

11.02300

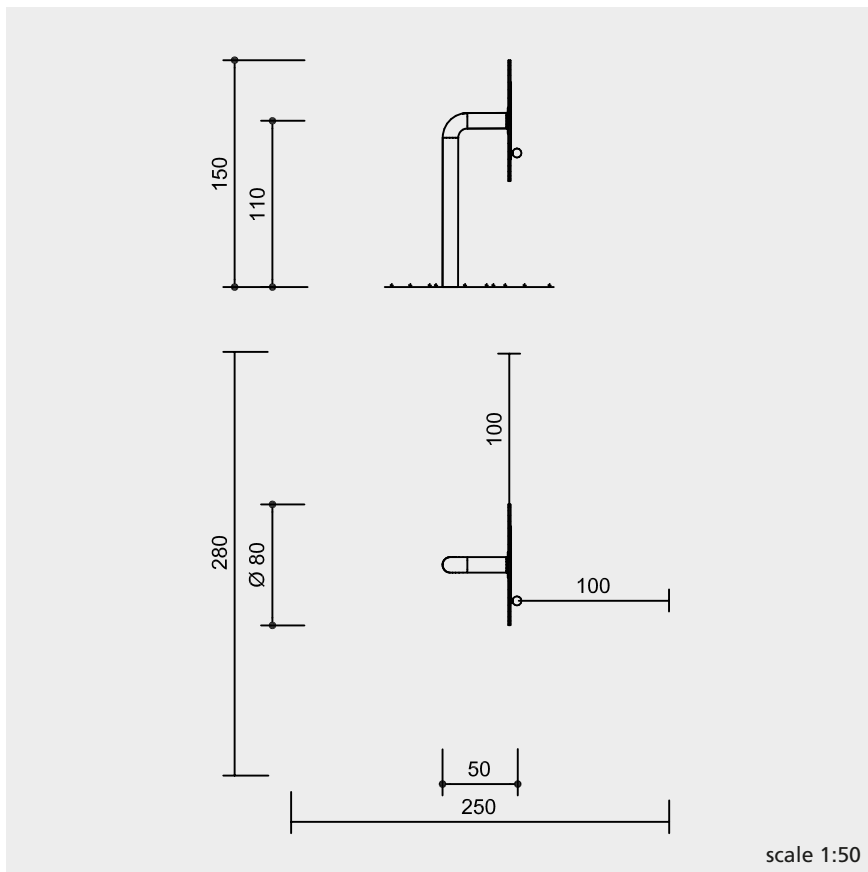

Technical information

equipment made of stainless steel

tube diameter 104 mm

thickness of disc 12 mm, made of natural anodised aluminium, mounted in sleeve bearings made of plastic

ball handle made of polyoxymethylene (POM-C), standard colour blue

Dimensions

(small deviations possible)

height	1.50 m
width	Ø 0.80 m
depth	0.50 m

weight approx. 30 kg

Safety

This equipment is not playground equipment within the scope of EN 1176 and therefore is also not subject to the requirements of this standard. Nevertheless, it is complied with where appropriate.

Components

1 completely assembled piece of equipment

Installation information

Surfacing
no requirements

Foundations
1 item 50 x 50 x 40 cm
excavation 60 cm

Attention!

Exact measurements may vary, for all installation dimensions refer to current installation instructions.
Subject to technical changes!

Equipment also available in bolt-on version.

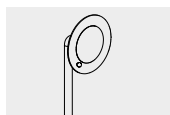

11.02300



Function

The Turning Capstan is a piece of equipment for stimulation, particularly of the hips. By taking a good grip of the handle, a risk-free light movement is made possible. The brain is challenged and mental and physical performances are improved.



Turning Capstan

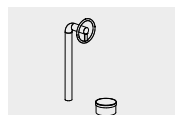

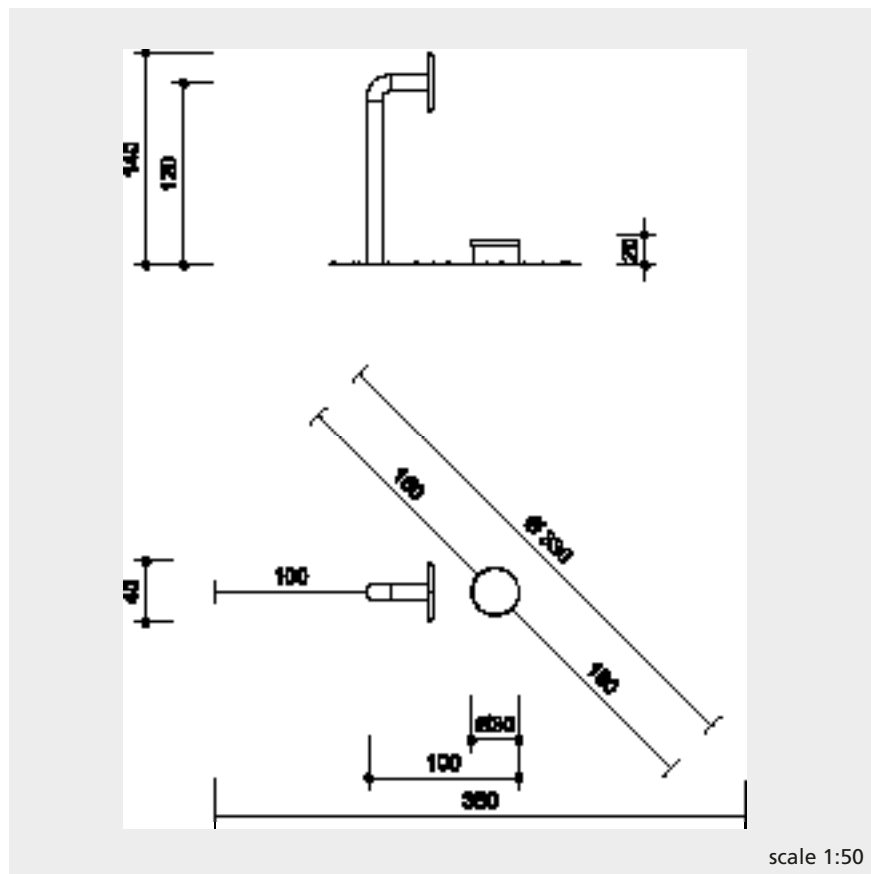

Technical information

equipment made of stainless steel

tube diameter 104 mm,
handle diameter 33.7 mm

standing plate made of polyoxymethylene (POM-C), standard colour blue

circular movement 45° in both directions, impact-absorbed stop

the resistance of the rotatable bollard adjusts to the user's weight

Dimensions

(small deviations possible)

equipment height	1.40 m
height of rotatable bollard	0.20 m
	Ø 0.30 m
width	0.40 m
weight	40 kg

Safety

This equipment is not playground equipment within the scope of EN 1176 and therefore is also not subject to the requirements of this standard. Nevertheless, it is complied with where appropriate.

Components

- 1 handle frame
- 1 turning capstan

Installation information

Surfacing
no requirements

Foundations
1 item 50 x 50 x 40 cm
excavation depth 60 cm
1 item 60 x 60 x 40 cm
excavation depth 60 cm

Attention!

Exact measurements may vary, for all installation dimensions refer to current installation instructions.

Subject to technical changes!

Equipment also available in bolt-on version.

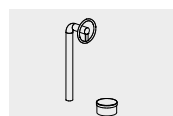

11.02400

Function

In the sitting position the Turning Seat is a comfortable and easy way to carry out hip mobility exercise. A good grip of the handle is easily maintained. The brain is stimulated and mental and physical performances are improved.



Turning Seat

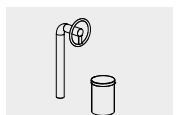

11.02500

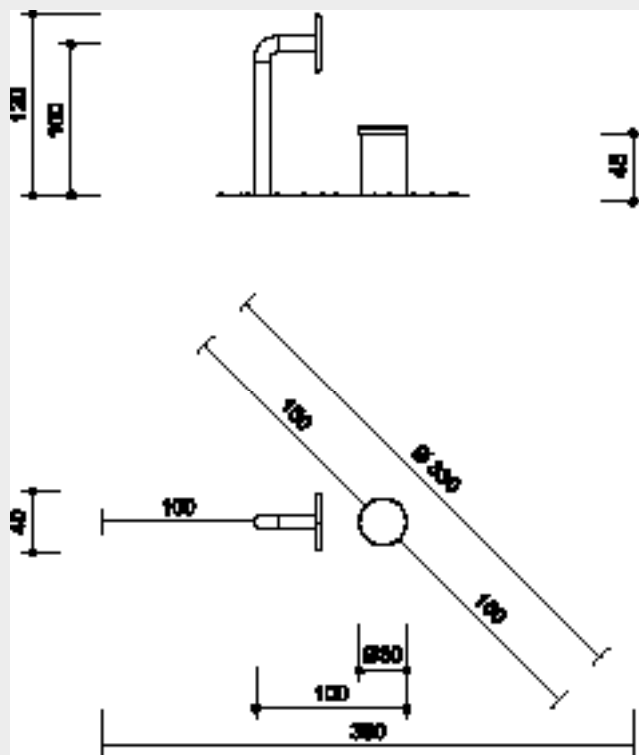

scale 1:50

Technical information

equipment made of stainless steel

tube diameter 104 mm
grip diameter 33.7 mm

seat plate made of polyoxymethylene (POM-C), standard colour blue

circular movement of rotatable seat 360 °

the resistance of the rotatable seat adjusts to the user's weight

Dimensions

(small deviations possible)

height	1.20 m
height of rotatable seat	0.45 m
	Ø 0.30 m
width	0.40 m
weight	40 kg

Safety

This equipment is not playground equipment within the scope of EN 1176 and therefore is also not subject to the requirements of this standard. Nevertheless, it is complied with where appropriate.

Components

1 handle frame
1 turning seat

Installation information

Surfacing
no requirements

Foundations
1 item 50 x 50 x 40 cm
excavation depth 60 cm
1 item 60 x 60 x 40 cm
excavation depth 60 cm

Attention!

Exact measurements may vary, for all installation dimensions refer to current installation instructions.

Subject to technical changes!

Equipment also available in bolt-on version.

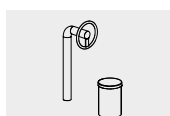

11.02500



Swinging Ball suspension technically modified.

Swinging Ball

Play value

This exercise can be conducted alone or with a partner. The aim is to throw and catch a ball which is suspended on a pendulum. The equipment is installed with buffers which prevent the ball hitting the player or their training partner. This exercise trains the movement of the hands, arms and shoulders. It contributes to improving mobility, reactions and the sense of rhythm. In addition, this exercise trains coordination and the playful aspect gets people used to working together.

Recommended for

- Young people
- Adults
- Older people
- Public play areas without supervision, such as playgrounds, parks or similar



Order No. 11.02600
Swinging Ball

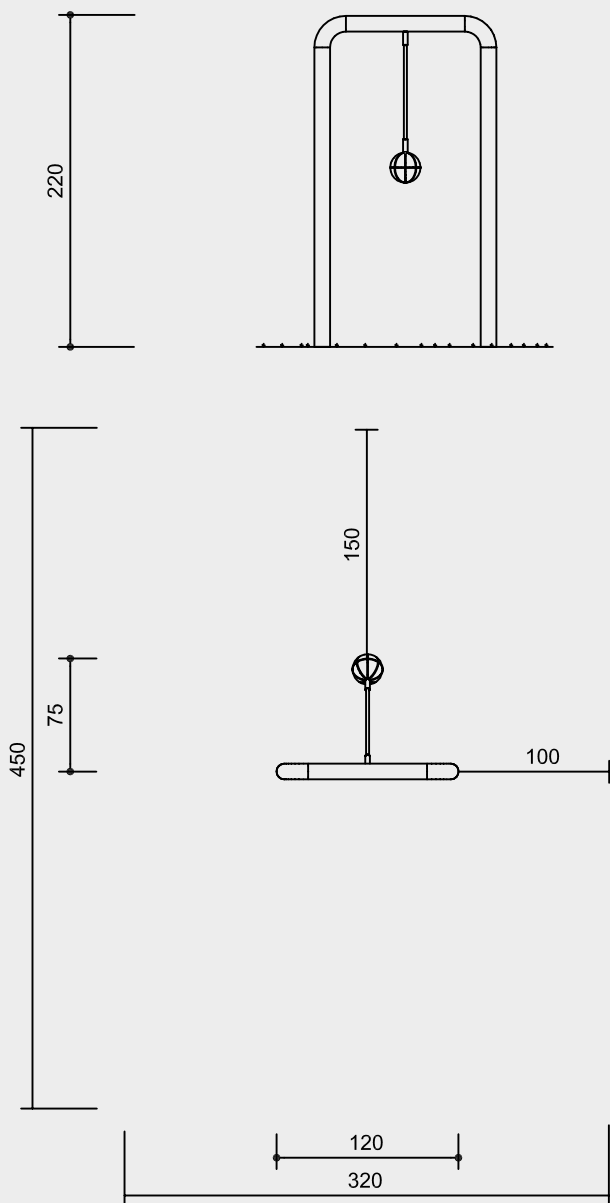

Technical information

Equipment made of stainless steel

Richter Hercules type rope

Richter Hercules type rope, a combination of galvanised six-strand steel cables and polyester yarn, diameter > 20 mm, laid and glued with very good abrasion resistance, strong sheathing even in the case of damage by puncturing



Aluminium rope pressing

Aluminium rope pressing, cylindrically pressed, with rounded ends



Chains

Chains made of hot-dip galvanized steel (1.4301 / 1.4571 at extra charge) welded before galvanising, short-linked, without eyelets on the connecting parts, easy to exchange and shorten



For more detailed explanation of the quality characteristics see price list.

Tube diameter 104 mm

Ball, diameter 20 cm, made of thick-walled, moisture-proof rubber material, standard colour blue

Dimensions

(small deviations possible)

Height	2.20 m
Width	1.20 m
Depth including oscillation to both sides	1.50 m
Weight approx.	40 kg

Safety

This equipment is not playground equipment within the scope of EN 1176 and therefore is also not subject to the requirements of this standard. Nevertheless, it is complied with where appropriate.

Components

1 Completely assembled piece of equipment

Installation information

Surfacing
no requirements

Foundations
2 items 50 x 50 x 40 cm
Excavation 60 cm

Attention:
Exact measurements may vary, for all installation dimensions refer to current installation instructions.
Technical changes reserved.



11.02600

Playground for young and old

Generationen-Aktiv-Park® - The cross-generation concept for promoting health in outdoor public areas. This is a complete concept which has been designed to be used by people of all ages. The Aktiv-Park equally unites physical, mental and social aspects. Special attention has been focused on the needs of older people.

The main focuses are:

- promoting contact between young and old
- strengthening physical health
- improving mental health

The park has been designed and tested by recognised experts according to the recommendations of the World Health Organisation.

Strengthening physical health

The human body has over 400 muscles. Sufficient and correct exercise keeps them healthy and effective. Muscles which are not exercised lose their effectiveness. Like decommissioned power stations they no longer need any of the fuel which is taken in as food. The result of this is an increasing tiredness of the body, continuously increasing body weight and a range of so-called lifestyle diseases. With the help of appropriate exercises the most important muscles can be strengthened. For younger people this is an important measure against the prevailing lack of exercise. Furthermore, targeted exercises lay the important foundation to preserve mobility and the quality of life for older people. Enjoyment and pleasure through exercise, preferably in a group, not only strengthens the muscles but also social communication and human relationships.

Improving agility and coordination

Even the most simple of exercises like, for example, walking, standing and gripping challenges the human body to a great degree. In complicated interactions between the senses, the brain and the muscles, millions of impulses are coordinated every second. The better this coordination works the easier everyday life becomes. Interplay between senses, brain and muscles can be positively influenced irrespective of age. With increasing age it is of critical importance to maintain agility and coordination. The challenging nature of the exercise as well as the fun and the enjoyment of trying out and practising together have equally important significance. In order to comprehensively increase agility the coordination between the eyes, ears, arms and legs need to be promoted to equal degrees.

Improving cognition and memory performance

"A healthy soul in a healthy body", the ancient Romans were already aware of it. That's why the brain and, equally, also the body need to be challenged in order to remain healthy and strong. Even the effort which is needed to carry out complicated processes in the human brain can be reduced by repeated targeted exercises. The result of this is that even difficult everyday tasks can be carried out more easily. Versatile demands and challenges of all the human brain's skills lay the key building blocks for mental health.

Practising everyday challenges

Exercises to improve overall well-being and to increase the quality of life have to be orientated towards daily life. For many people seemingly easy to carry out tasks become almost insurmountable challenges. These include walking long distances and climbing stairs. At the stations, which relate to everyday tasks, children and infants can explore and learn their boundaries in a playful way. Older people have the opportunity to improve their everyday-relevant agility within a safe environment. At the same time the heart and the circulatory system are being trained and stamina is improved.

You will find an example of a course on page 38.

Information about the term “cross-generation”

The term “**cross-generation**” isn’t anything new or special but is rather a matter of course for all those people whose work involves shaping policy in society.

It is important to avoid creating ghettos and important to make it clear that there are dangers in seeking simple solutions for one dimensional aspects only.

Everything separate has the hidden disadvantage of being an isolated action, the special/extra is often a reaction to previous failures. Togetherness has to be our goal right from the start of our actions and should not suffer any of the disadvantages of having to compromise due to having to alter things afterwards. Cooperation is of great value and must be encouraged.

When a term like “**cross-generation**” first comes into being, then it is particularly important to develop a common consciousness about what is meant by it.

Does it mean:

- something for every age group?
- and/or that there are articles for the elder and yet more elderly people for physical and mental training?
- so that when the question “who plays/who plays with whom” is examined, then it is important to look at which age group is meant:
- small children/children with parents?
- small children/children with grandparents?
- parents/with grandparents?
- or the individual age groups separately?

Is being together to be understood as

- being at the same place
- and/or at the same time or
- really to play/react with each other: interact with each other at the same place and time and act as an inspiration to each other to have fun and enjoyment?

It is difficult to find play equipment suitable for real cross-generational interaction. Naturally, the principle that the common space should be a place of well-being also applies here. It is only then that it can be about finding objects which make such enjoyable cooperation a possibility.

Above all public spaces are shared spaces. Their main focus should be equipment for

- children
- parents
- senior citizens

and offers for common use.

The aim has to be that people feel comfortable together and gain enjoyment from each other’s closeness and common usage. By closeness also the spatial closeness is meant. When defining cooperation of use what is above all to note is that

- children can use the public space to play in
- adults can behave in a very functionally orientated way in the public space
- a particular emphasis is put on making sure that the designed area enables and promotes playing together.

The term “**cross-generation**” is also often used when we want to take the senior citizen group into consideration.

We define four main motivations for senior citizen activities:

- keeping the senses active
- keeping physical fitness/mobility
- dealing with mental and/or physical limitations
- adopting a therapeutic approach.



Effect

The leg press serves to improve the strength in the largest and most important leg and gluteal muscles. At the same time good bone condition is promoted.



Purpose

From our first steps onwards our legs carry us through life. That's why healthy legs are essential for independence and mobility. Our muscles serve thereby as the motor. Just simply stretching and bending the legs with a light load keeps this motor going and gets it up to speed. Not only do the muscles react positively to this but also the bones become more robust and resilient.

Function

People are all different. Whether they're old or young, trained or untrained our intelligent, yet also simple system "thinks" with you. The resistance automatically adjusts itself to the level of strength of the person exercising. Easy to read exercise instructions aid optimal usage.

Leg Press

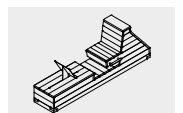

11.50100

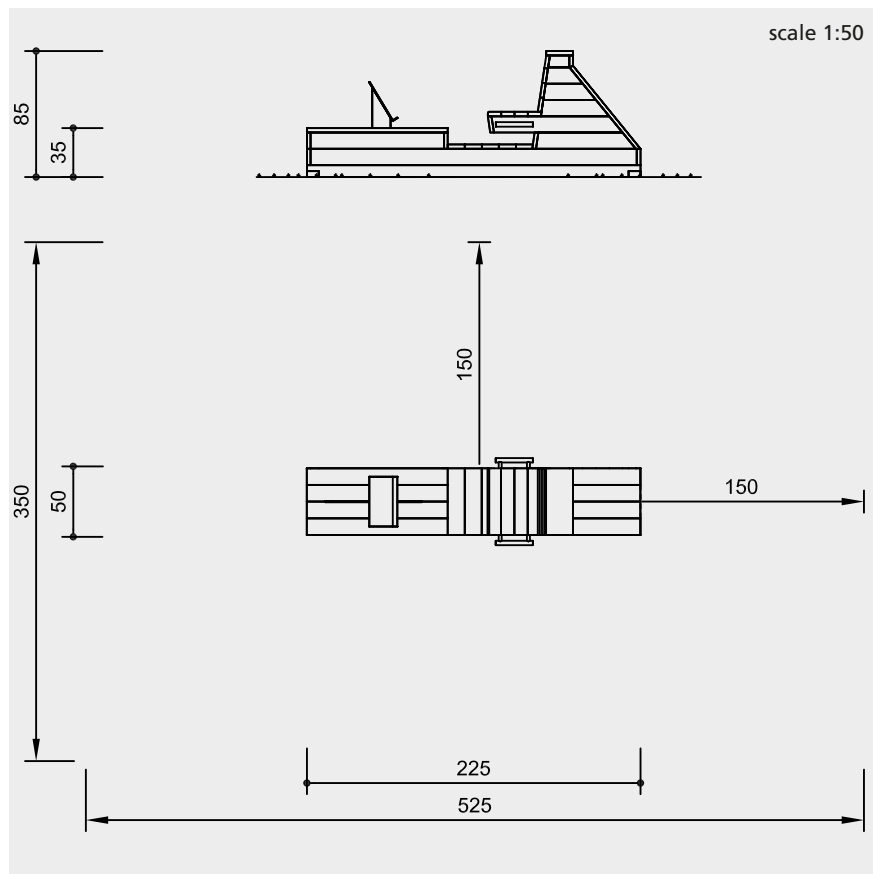

Technical information

Core-free timber

sawn-timbers of mountain larch, selected according to eight quality criteria, core-free thus decreasing the occurrence of cracking



hot dip galvanised substructure

handles made of stainless steel

support panel for footrest hot dip galvanised, painted in various colours, standard colour yellow

footrest made of solid coloured polyethylene (PE)

Dimensions

(small deviations possible)

height	0.80 m
length	2.05 m
width	0.50 m
weight	210 kg

Safety

This equipment is not playground equipment within the scope of EN 1176 and therefore is also not subject to the requirements of this standard. Nevertheless, it is complied with where appropriate.

For more detailed explanation of the quality characteristics see price list.

Components

- 1 leg press
- 2 heavy duty bolts

Installation information

Surfacing corresponding to a fall height ≤ 0.60 m

Foundations
1 item 140 x 40 x 35 cm
excavation depth 35 cm

Attention!
Exact measurements may vary, for all installation dimensions refer to current installation instructions.
Subject to technical changes!

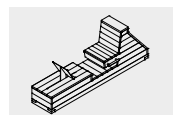

11.50100

Effect

Strengthening of the arms, shoulders, chest and trunk musculature. The most important muscles of the whole upper body are activated and trained. Bone formation is stimulated positively.

Purpose

Lifting, carrying, pushing and pulling are everyday movements. These movements would be impossible without the strength of our hands, arms, and shoulders.



However, one-sided stress too often leads to problems and disorders. The rowing movement is ideally suited for strengthening the associated muscles comfortably and efficiently. Weakened muscles are once again strengthened and muscular imbalance is counteracted.

Function

Whether juniors, seniors or professionals, our intelligent yet also simple system "thinks" with you. As opposed to rowing in water the resistance automatically adjusts to the level of strength of the training person. Those exercising can row either in the direction with or against the "course". In this way, in addition to the arm and shoulder muscles also the stomach and back muscles are similarly used. Easy to read exercise instructions aid optimal usage.

Rowing Machine

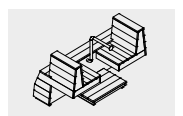

11.50101

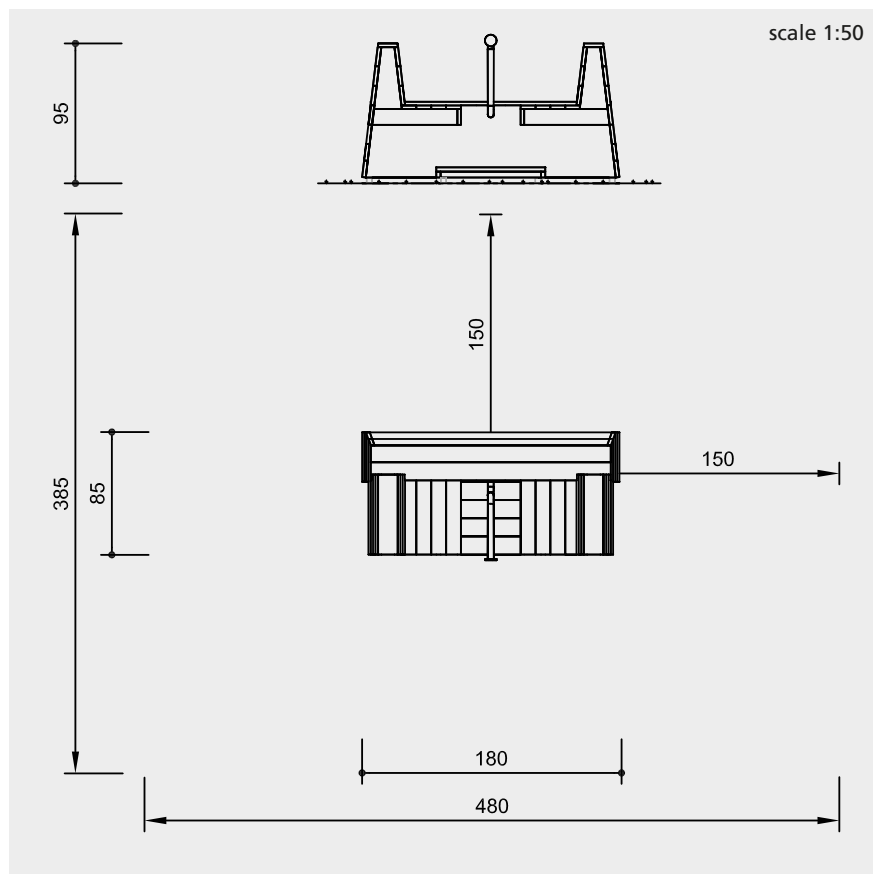

Technical information

Core-free timber

sawn-timbers of mountain larch, selected according to eight quality criteria, core-free thus decreasing the occurrence of cracking



hot dip galvanised substructure

handle bar made of stainless steel

Dimensions

(small deviations possible)

height	0.90 m
length	1.55 m
width	0.85 m
weight	150 kg

Safety

This equipment is not playground equipment within the scope of EN 1176 and therefore is also not subject to the requirements of this standard. Nevertheless, it is complied with where appropriate.

For more detailed explanation of the quality characteristics see price list.

Components

- 1 rowing machine
- 2 heavy duty bolts

Installation information

Surfacing corresponding to a fall height ≤ 0.60 m

Foundations
1 item 170 x 80 x 35 cm
excavation depth 35 cm

Attention!

Exact measurements may vary, for all installation dimensions refer to current installation instructions.

Subject to technical changes!

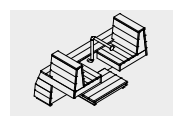

11.50101

Effect

The Boxing Bike improves the strength and endurance of the whole body. The arm, leg and trunk musculature are exercised at the same time. Strength, endurance and coordination are maintained to equal degrees. The effect is an overall activation of the entire organism.

Purpose

You don't get very far just with strength alone. In everyday life stamina is just as important. Leg and arm coordination is also essential. Walking for a long time or climbing up to the third floor carrying the shopping requires strength, stamina and agility. In the process the muscles, heart and circulation all have to perform together; the arms and legs need to cooperate. Bike riding, which requires all these elements at the same time, is therefore optimal for health.

Function

It doesn't matter who sits on the Boxing Bike, our intelligent yet also simple system "thinks" with you. The resistance for arms and legs automatically adjusts itself to the level of strength of the persons training. The fixed seating height is suitable for small and large people. Easy to read exercise instructions aid optimal usage.



Boxing Bike

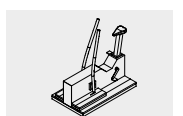

11.50102

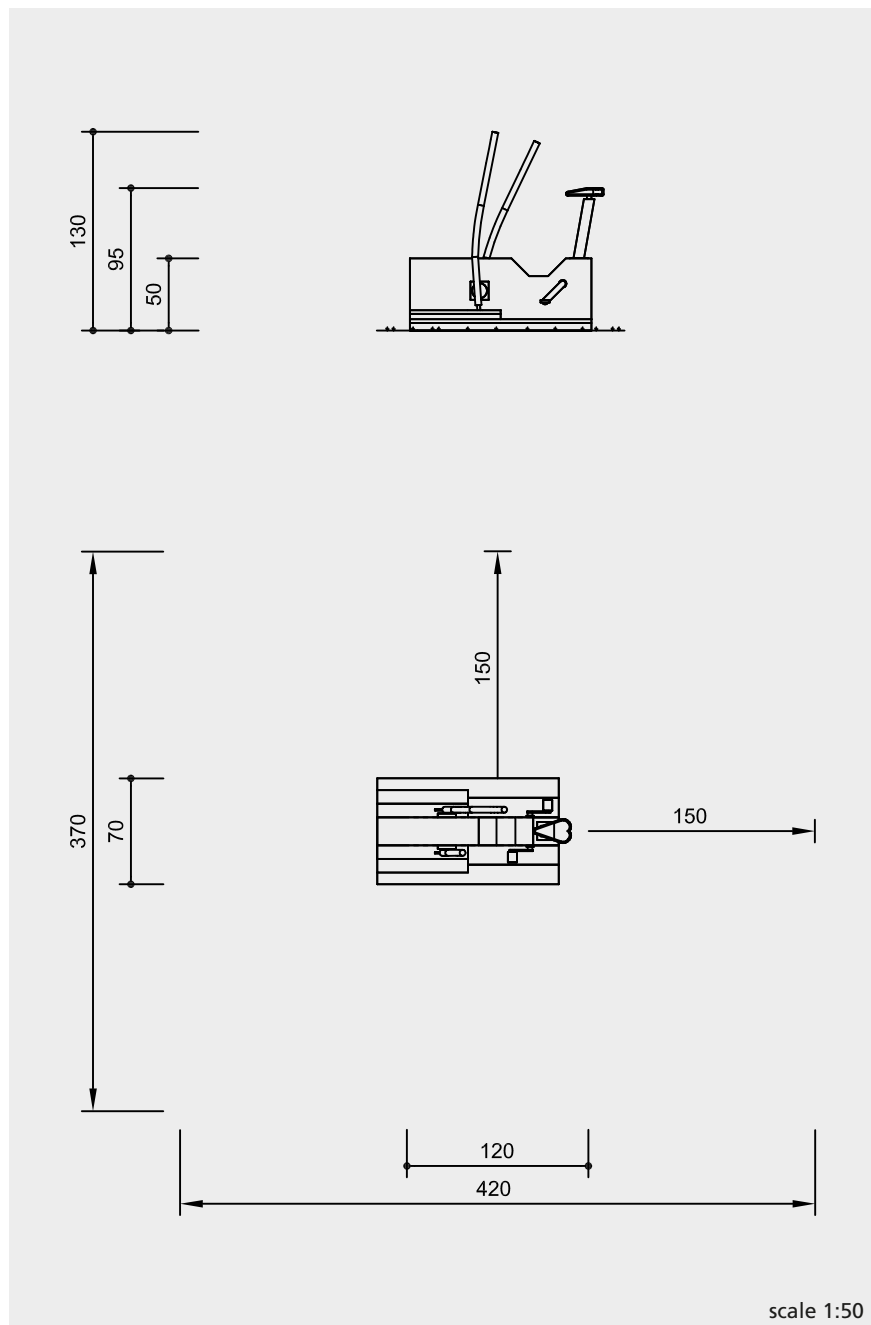

Technical information

Core-free timber

sawn-timbers of mountain larch, selected according to eight quality criteria, core-free thus decreasing the occurrence of cracking



brass bush

for all to and fro movements we use bush bearings which allow for self-lubrication while in use and which can be easily exchanged in case of need



hot dip galvanised substructure

bars made of stainless steel

handles made of oak

saddle made of leather

Dimensions

(small deviations possible)

height	1.30 m
length	1.20 m
width	0.70 m
weight	125 kg

Safety

This equipment is not playground equipment within the scope of EN 1176 and therefore is also not subject to the requirements of this standard. Nevertheless, it is complied with where appropriate.

For more detailed explanation of the quality characteristics see price list.

Components

- 1 boxing bike
- 2 heavy duty bolts

Installation information

Surfacing corresponding to a fall height ≤ 0.60 m

Foundations
1 item 116 x 66 x 35 cm
excavation depth 35 cm

Attention!
Exact measurements may vary, for all installation dimensions refer to current installation instructions.
Subject to technical changes!

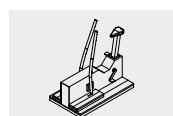

11.50102

Effect

The Stomach and Back Trainer improves the trunk musculature. On the one hand, a healthy balance between both the muscle groups is established. And on the other hand, strength levels are increased by the targeted activities.

Purpose

Too much sitting and not enough exercise are the main causes of back pain. But what can be done about this lifestyle disease? The best protection against this problem is a well-developed trunk musculature.



Copyright © Richter Spielgeräte GmbH 03/15

Licensor Moser Spielgeräte GmbH

To achieve this, stomach and back muscles need to be uniformly exercised and trained in a targeted way. The best way is to exercise before any pain starts. However, even if pain exists exercise is often the best medicine.

Function

A gentle resistance promotes the back musculature and supports the stomach muscles at the same time. This principle follows the scientific finding that both muscle groups need to be exercised in different ways. "Exercised but not over-exercised" is the principle. The exercise is carried out in a comfortable sitting position. Easy to read exercise instructions aid optimal usage.

Stomach and Back Trainer



11.50103

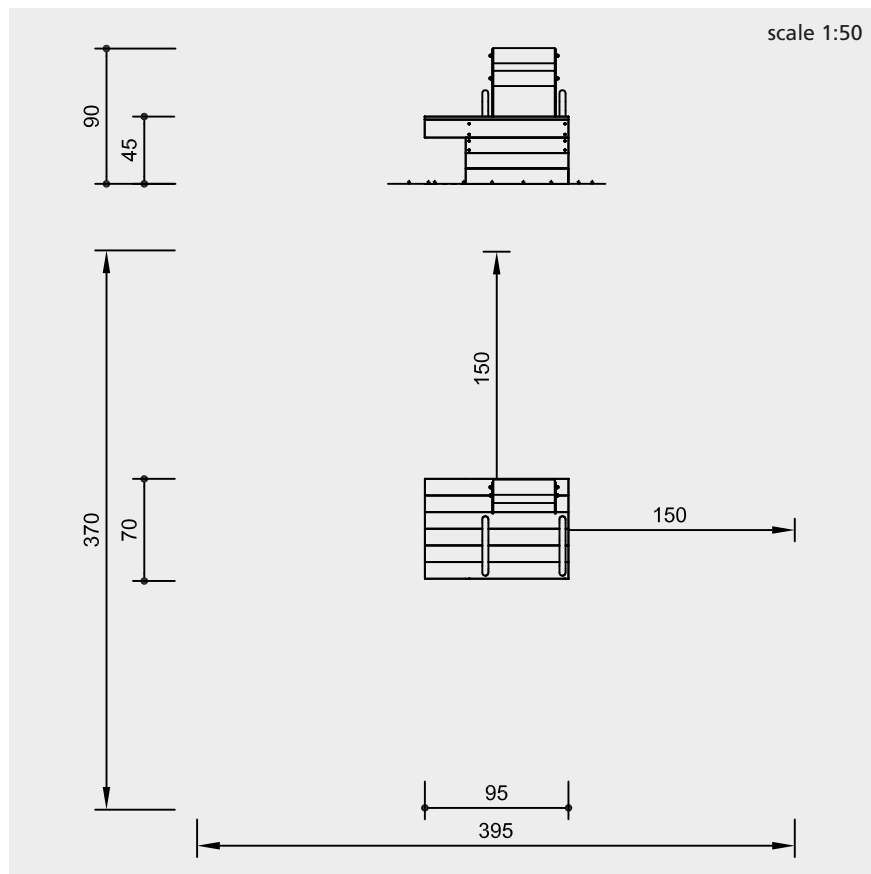

Technical information

Core-free timber

sawn-timbers of mountain larch, selected according to eight quality criteria, core-free thus decreasing the occurrence of cracking



hot dip galvanised substructure

grips and back rest made of stainless steel

cushion made of EPDM, standard colour yellow

Dimensions

(small deviations possible)

height	0.90 m
length	0.95 m
width	0.65 m
weight	105 kg

Safety

This equipment is not playground equipment within the scope of EN 1176 and therefore is also not subject to the requirements of this standard. Nevertheless, it is complied with where appropriate.

For more detailed explanation of the quality characteristics see price list.

Components

- 1 stomach and back trainer
- 2 heavy duty bolts

Installation information

Surfacing corresponding to a fall height ≤ 0.60 m

Foundations
1 item 60 x 50 x 35 cm
excavation depth 35 cm

Attention!

Exact measurements may vary, for all installation dimensions refer to current installation instructions.

Subject to technical changes!



11.50103



Effect

The Ball Game promotes balance and improves the coordination between the eye and leg. At the same time the leg musculature is strengthened and mobility is improved.

Purpose

It is important to be able to stand safely on one leg. This skill helps to prevent falls and avoid serious injuries. However practising standing on one leg is often difficult and no fun at all. That is, unless an exciting and entertaining task is set up. It is best to train in a group.

Function

Standing on one leg improves the sense of balance and strengthens the musculature. Moving the ball in its track also simultaneously trains the coordination and the interplay between the eye and leg. For children as well as adults this is a difficult but at the same time entertaining task. Easy to read exercise instructions aid optimal usage.



Ball Game

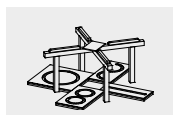

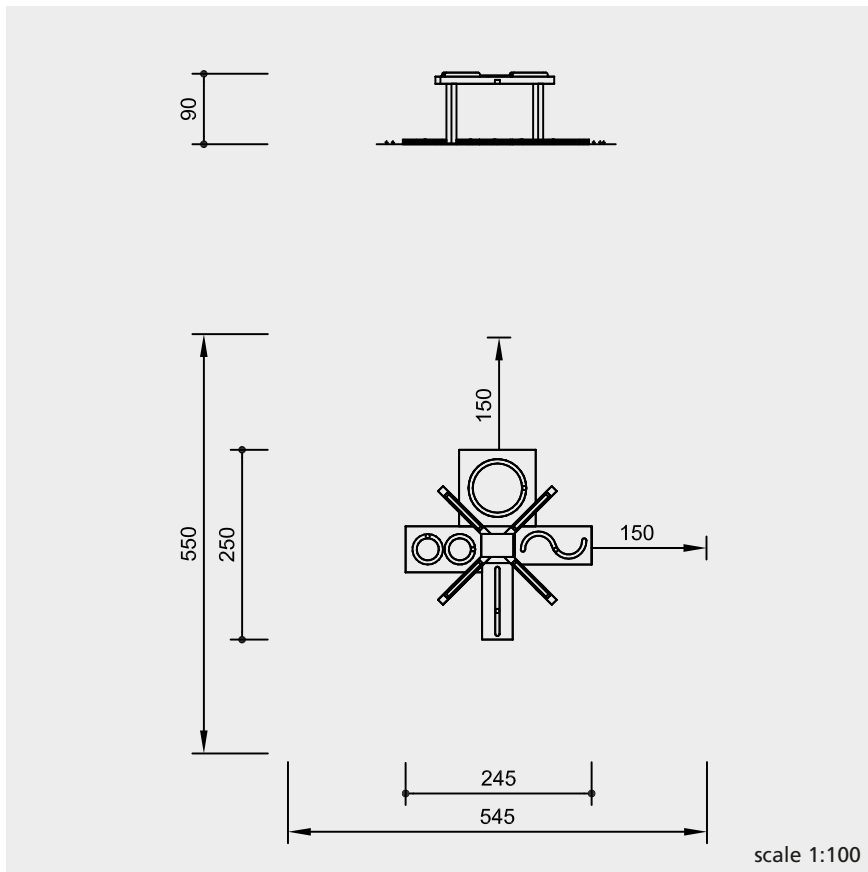

Technical information

Core-free timber

sawn-timbers of mountain larch, selected according to eight quality criteria, core-free thus decreasing the occurrence of cracking



Ground anchor

hot dip galvanised steel feet



substructure made of stainless steel brackets

support panel for balls made of solid coloured polyethylene (PE) standard colour yellow

balls made of hard plastic

Dimensions

(small deviations possible)

height 0.90 m
length 2.45 m
width 2.45 m

weight approx. 145 kg

Safety

This equipment is not playground equipment within the scope of EN 1176 and therefore is also not subject to the requirements of this standard. Nevertheless, it is complied with where appropriate.

Components

- 1 equipment with 4 ball boards
- 1 handrail
- 5 steel feet

Installation information

Surfacing corresponding to a fall height < 0.60 m

- Foundations each 1 item
- 98 x 100 x 15 cm
- 58 x 98 x 15 cm
- 48 x 98 x 15 cm
- 38 x 98 x 15 cm
- excavation each 15 cm
- excavation for handrail
- 4 x 35 x 35 x 25 cm
- excavation depth each 45 cm

Attention!

Exact measurements may vary, for all installation dimensions refer to current installation instructions.

Subject to technical changes!

For more detailed explanation of the quality characteristics see price list.

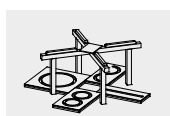

Effect

The Kling Klang improves the interplay between eyes, ears, arms and legs. Complex tasks can be solved in a playful way. The brain is stimulated and mental and physical performance is improved.

Purpose

Eyes and ears deliver important information about our environment. They help with orientation and influence the movements of our arms, hands and legs. The better the interplay the easier our everyday lives are. Regular, reasonable usage delivers an important stimulus to our minds and body.

Function

Sounds ring out and melodies can be played. This will only function, however, if the arms, legs and eyes work exactly together. If the task is not correctly solved then no sound is heard. The exercise can only be done by using the corresponding pedals together with the correct hand push button. Easy to read exercise instructions and challenging tasks make this station great fun for young and old.



Kling Klang



11.50201

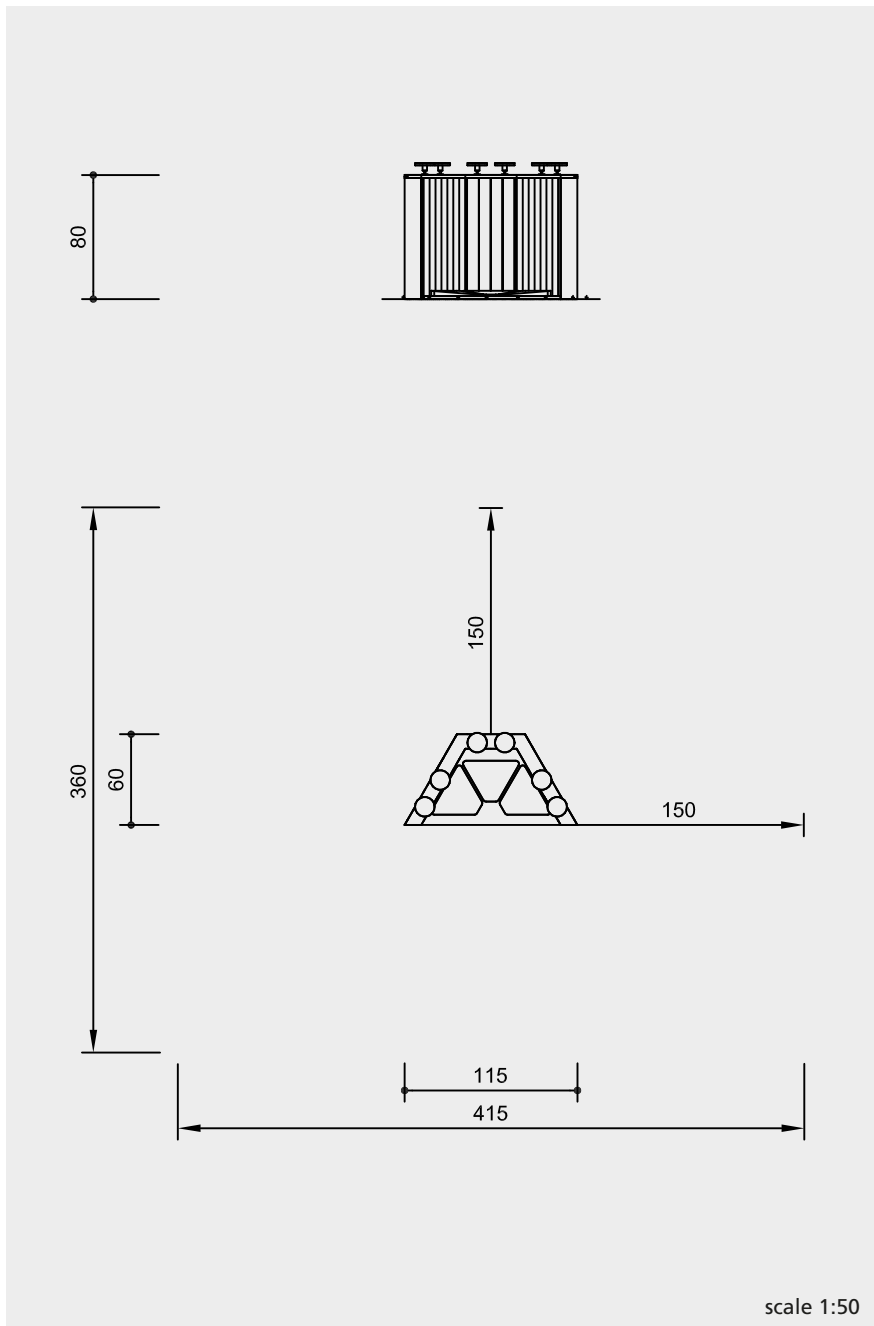

Technical information

Core-free timber

sawn-timbers of mountain larch, selected according to eight quality criteria, core-free thus decreasing the occurrence of cracking



hot dip galvanised substructure

pedals and hand push button made of solid coloured polyethylene (PE) standard colours yellow, blue, red

Dimensions

(small deviations possible)

height 0.80 m
length 1.15 m
width 0.60 m

weight approx. 80 kg

Safety

This equipment is not playground equipment within the scope of EN 1176 and therefore is also not subject to the requirements of this standard. Nevertheless, it is complied with where appropriate.

For more detailed explanation of the quality characteristics see price list.

Components

- 1 Kling Klang
- 2 heavy duty bolts

Installation information

Surfacing corresponding to a fall height < 0.60 m

Foundations
1 item 105 x 50 x 35 cm
excavation 35 cm

Attention!
Exact measurements may vary, for all installation dimensions refer to current installation instructions.
Subject to technical changes!



11.50201

Effect

The Street Car promotes balance. The change from being balanced to being unbalanced improves the coordination of the legs, the eyes and the sense of balance in an everyday-like situation.

Purpose

It's not difficult to stand with both legs on the ground. But if the ground starts moving it's no longer that easy. It is quite difficult to keep your balance in a moving bus, a street car or in the train. The body goes through a learning process by consciously experiencing and feeling moments where balance is lost. It is only through exercise in a secure environment that the necessary stability can be gained.

Function

A wobbly disc needs to be held in balance. The degree of difficulty can be selected individually. With or without holding on with the hands, with open or closed eyes, it is up to the person exercising to choose. The exercise is an entertaining challenge for young or old. Easy to read exercise instructions aid optimal usage.



Street Car



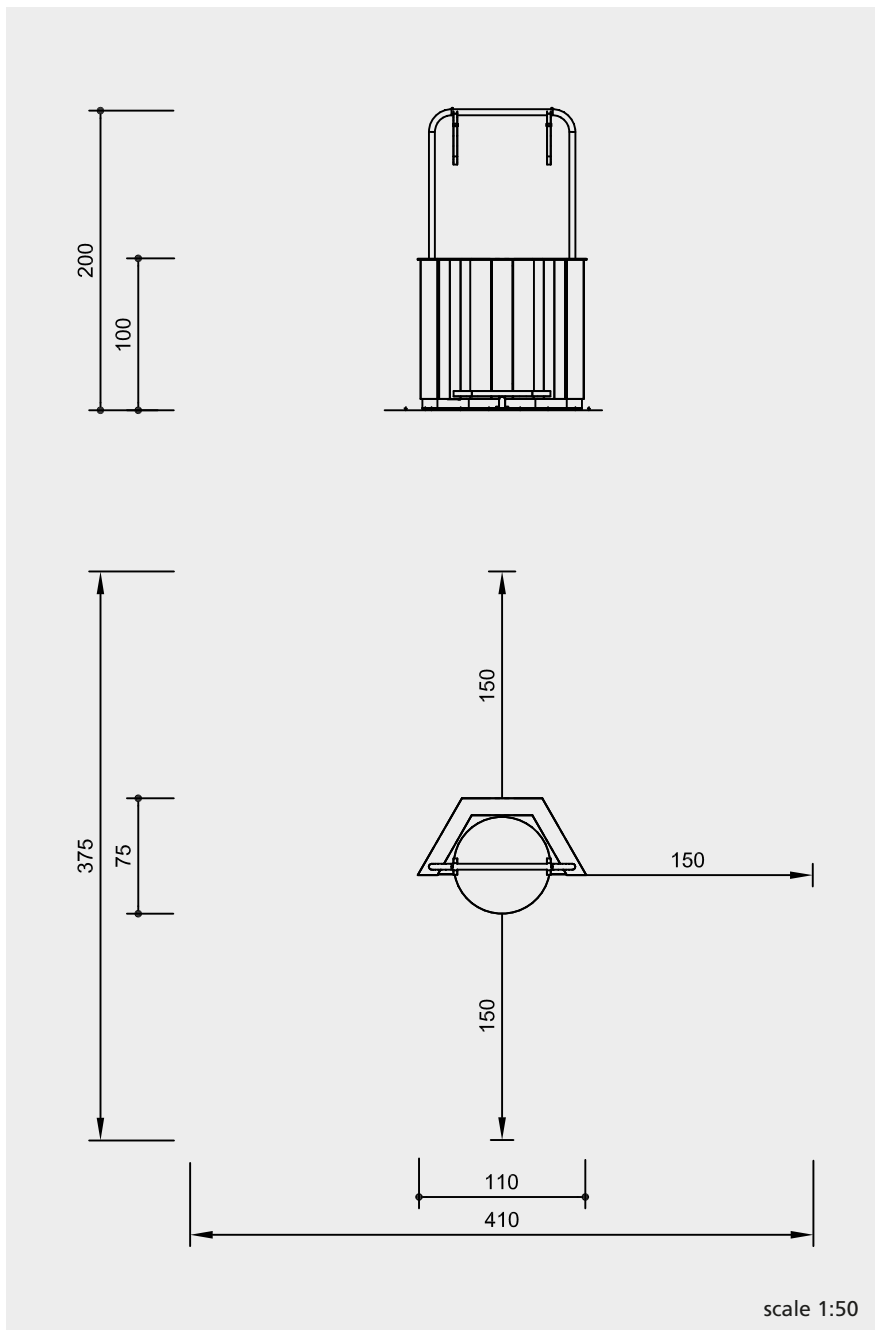

Technical information

Core-free timber

sawn-timbers of mountain larch, selected according to eight quality criteria, core-free thus decreasing the occurrence of cracking



brass bush

for all to and fro movements we use bush bearings which allow for self-lubrication while in use and which can be easily exchanged in case of need



hot dip galvanised substructure

grip bar made of stainless steel

handle straps made of plastic

wobbling dish made of hot dip galvanised textured metal, painted in various colours, standard colour yellow

Dimensions

(small deviations possible)

height 2.00 m
length 1.10 m
width 0.75 m

weight approx. 80 kg

Safety

This equipment is not playground equipment within the scope of EN 1176 and therefore is also not subject to the requirements of this standard. Nevertheless, it is complied with where appropriate.

For more detailed explanation of the quality characteristics see price list.

Components

- 1 street car
- 2 heavy duty bolts

Installation information

Surfacing corresponding to a fall height < 0.60 m

Foundations
1 item 105 x 50 x 35 cm
excavation 35 cm

Attention!
Exact measurements may vary, for all installation dimensions refer to current installation instructions.
Subject to technical changes!



11.50202

Effect

The Balancing Path promotes balance and safety when walking. Balancing improves the interplay between the legs and the balancing system.

Purpose

Standing means staying in balance. When you walk you have to leave this status. So as not to fall over this imbalance needs to be mastered. Safe and fall-free movement can therefore be improved by suitable and controlled training. Thus, it is important to exercise in a secure environment as well as to solve tasks of various difficulties.



Function

Walking over narrow bars and posts promotes the sense of balance. The low height takes away the fear of making a wrong step. The soft ground surfacing and the handrails on either side ensure the greatest safety and minimises the danger of injury. Easy to read exercise instructions aid optimal usage for young and old.

Balancing Path

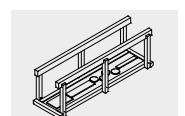

11.50203

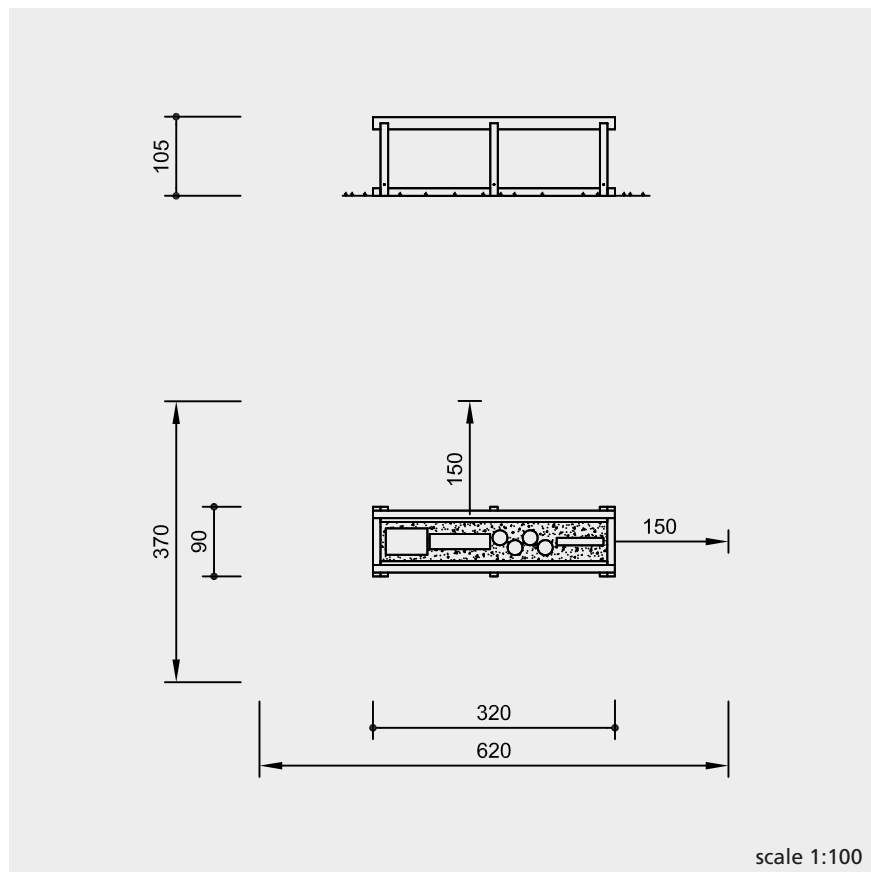

Technical information

Core-free timber

sawn-timbers of mountain larch, selected according to eight quality criteria, core-free thus decreasing the occurrence of cracking



anchoring to the ground

all parts used for anchoring to the ground made of hot-dip galvanised steel



Dimensions

(small deviations possible)

height	1.05 m
length	3.20 m
width	0.90 m
weight	155 kg

Safety

This equipment is not playground equipment within the scope of EN 1176 and therefore is also not subject to the requirements of this standard. Nevertheless, it is complied with where appropriate.

For more detailed explanation of the quality characteristics see price list.

Components

- 1 balancing path with permanently attached balancing element (to be filled with e.g. wood chips on site)
- 4 steel feet

Installation information

Surfacing
no requirements
recommended:
wood chips, granular material or the like

Foundations
4 items 40 x 40 x 35 cm
excavation depth 55 cm

Attention!

Exact measurements may vary, for all installation dimensions refer to current installation instructions.

Subject to technical changes!

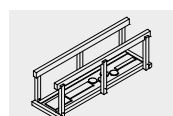

11.50203



Effect

The stations for training the mind improve learning, thought and memory performance. The exercises result in a comprehensive promotion of a range of skills of the human brain.

Best.-Nr. 11.50301 Information Board



Purpose

The brain is our most important organ. In order for it to remain efficient it needs regular external influences. Just like our muscles, our brains need to be stimulated in order for them to keep working properly. However, this stimulation needs to be varied and balanced. That's why it is important to equally challenge all the five abilities of our brain.

Function

Stations to increase the powers of concentration, cognition, memory, word finding and perception promote the "grey cells". A range of exercises with different degrees of difficulty offer a challenge for young and old. The corresponding answers can be found on the back of each station.

Training the Mind Information Board



11.50300

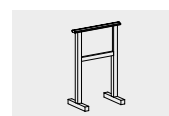

11.50302



11.50301

**Order No.
11.50300**

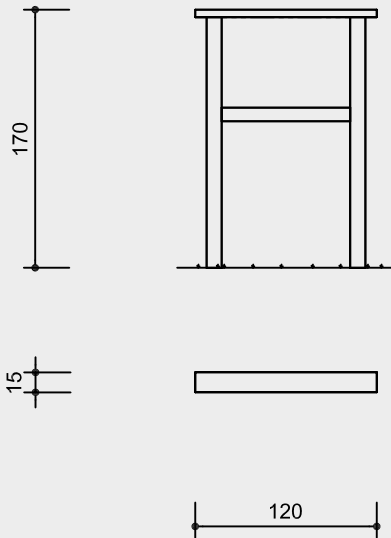

**Order No.
11.50301**

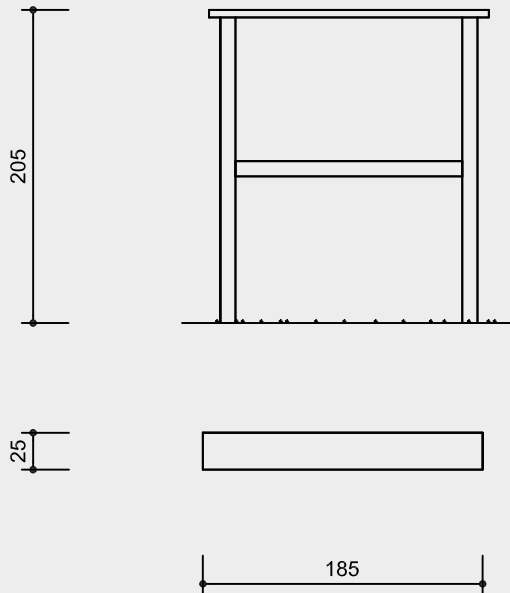

scale 1:50

Technical information

Core-free timber

sawn-timbers of mountain larch, selected according to eight quality criteria, core-free thus decreasing the occurrence of cracking



anchoring to the ground

all parts used for anchoring to the ground made of hot-dip galvanised steel



board with protective film

Dimensions

(small deviations possible)

Order No. 11.50300

height 1.70 m
length 1.20 m
depth 0.15 m
weight 40 kg

Order No. 11.50302

as before but
depth 0.75 m

Order No. 11.50301

height 2.05 m
length 1.85 m
depth 0.25 m
weight 25 kg

Safety

This equipment is not playground equipment within the scope of EN 1176 and therefore is also not subject to the requirements of this standard. Nevertheless, it is complied with where appropriate.

For more detailed explanation of the quality characteristics see price list.

Components

Order No. 11.50300

Training the Mind

1 frame for in-situ concrete
2 steel feet
4 seasons boards to exchange

Order No. 11.50302

Training the Mind

1 frame for bolt-on version
4 seasons boards to exchange

Order No. 11.50301

Information Board

1 frame
2 steel feet

Installation information

Surfacing
no requirements

Foundations
2 items 30 x 30 x 20 cm
excavation depth 40 cm

Order No. 11.50302

for bolt-on version

Attention!

Exact measurements may vary, for all installation dimensions refer to current installation instructions.

Subject to technical changes!



11.50300



11.50302



11.50301

Effect

Climbing stairs promotes stamina and mobility. Everyday challenges can be practiced in the form of various exercises. Safety in daily life is thereby improved and mobility increased.

Purpose

Everyday life can often contain hazards. Climbing stairs, descending stairs, stepping over obstacles, racing from one place to another. For a child a step can be an obstacle which is almost impossible to overcome. For older people an uneven path can pose a dangerous challenge.



Those who are prepared for these hazards can master everyday life with happiness and safety. Specifically designed exercises promote mobility and make independent living easier.

Function

The stations, based on real-life situations, invite you to try them out and exercise. Alongside agility, stamina is also trained in this circuit course. The path is set up so that not all the obstacles need to be overcome and so that an accompanying person can give best possible help. Handrails on both sides at every station additionally ensure the highest safety.

Life Path
Climbing Stairs

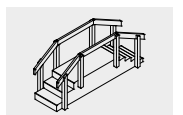

11.50400

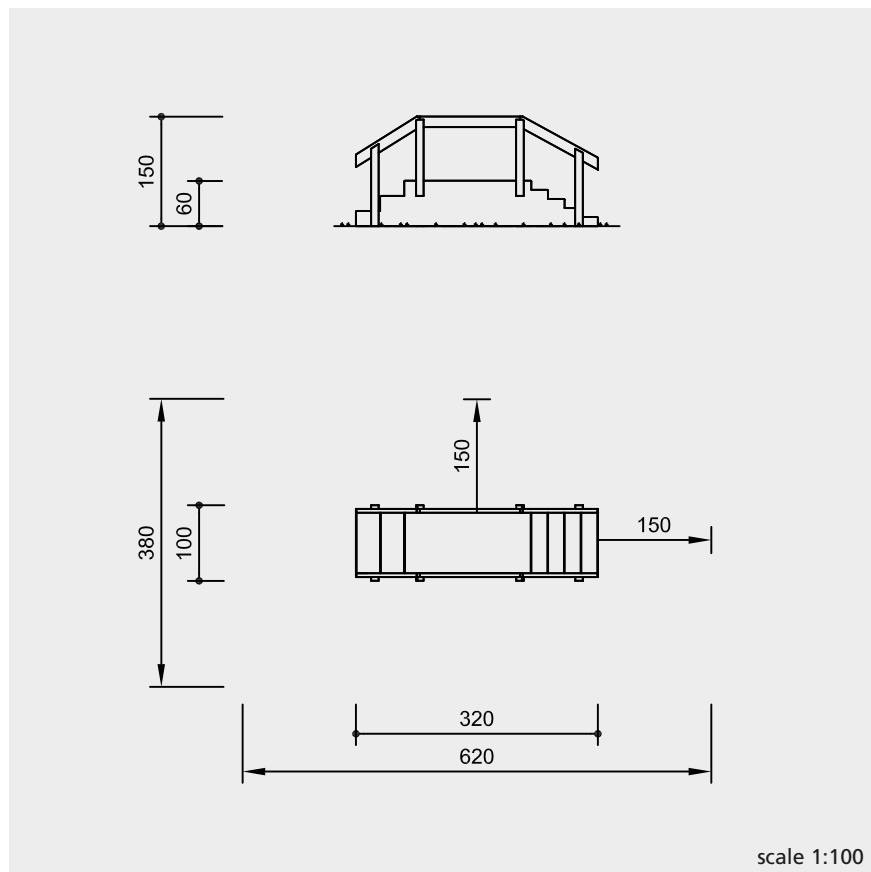

Technical information

Core-free timber

sawn-timbers of mountain larch, selected according to eight quality criteria, core-free thus decreasing the occurrence of cracking



anchoring to the ground

all parts used for anchoring to the ground made of hot-dip galvanised steel



Dimensions

(small deviations possible)

height	1.50 m
length	3.20 m
width	1.00 m
weight	200 kg

Safety

This equipment is not playground equipment within the scope of EN 1176 and therefore is also not subject to the requirements of this standard. Nevertheless, it is complied with where appropriate.

For more detailed explanation of the quality characteristics see price list.

Components

- 1 piece of equipment
- 4 steel feet

Installation information

Surfacing
corresponding to a fall height of ≤ 0.60 m recommended:
wood chips, granular material or the like

Foundations
4 items 50 x 50 x 35 cm
excavation depth 55 cm

Attention!
Exact measurements may vary, for all installation dimensions refer to current installation instructions.
Subject to technical changes!

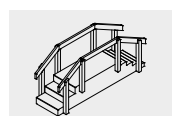

11.50400

Play Stations for Developing the Senses

Promotion of perception and the senses according to Hugo Kükelhaus

The topic play and perception is relevant to all of us, irrespective of age. It allows inner flexibility and freedom to adapt to the continuous changes which the paths of our life demands. The play stations are the instruments which activate this inner flexibility and allow us to focus on the wonderful phenomenon of nature.

Normally we adults just brush over such sensory impressions. By playing without any pressure to perform everyday life can be given a new significance; an ordinary day can turn into a special day. Seeing and hearing, smelling and feeling turns reality into what the word "real" implies: the special, the royal. This is the way in which the stations help to develop the senses.

As we grow older why can't we once again learn that childish sense of wonder and the pleasure which arises out of that wonder? That would make us all more appealing to others!

This equipment generally falls outside the scope of EN 1176, Safety of Playground Equipment. Nevertheless, where appropriate the requirements of this standard are respected.

Effect

Various tasks mean that everyday challenges can be practiced; stamina and agility are promoted. Safety in daily life is thereby improved and mobility increased.

Purpose

Everyday life can contain various hazards. Climbing stairs, descending stairs, stepping over obstacles, racing from one place to another. For a child a step can be an obstacle which is almost impossible to overcome. For older people an uneven path can pose a dangerous challenge.



Those who are prepared for these hazards can master everyday life with happiness and safety. Specifically designed exercises promote mobility and make independent living easier.

Function

The stations, based on real-life situations, invite you to try them out and exercise. Alongside agility, stamina is also trained in this circuit course. The path is set up so that not all the obstacles need to be overcome and so that an accompanying person can give best possible help. Handrails on both sides at every station additionally ensure the highest safety.

Life Path
Steps/Ramp

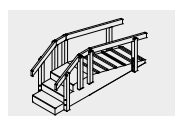

11.50401

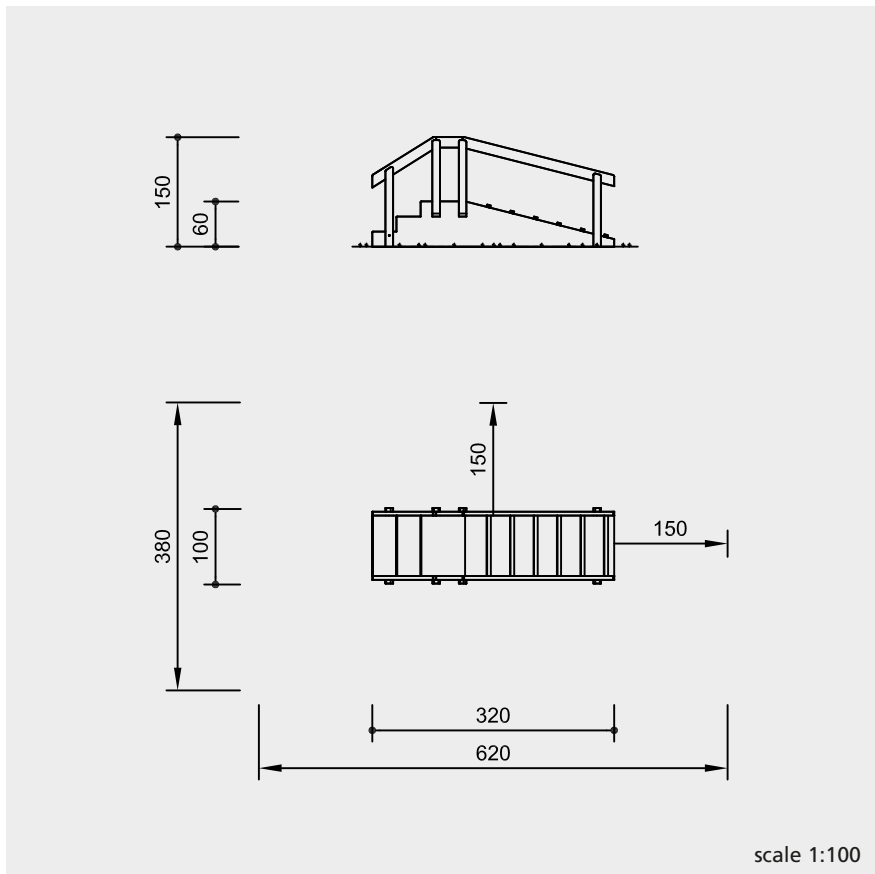

Technical information

Core-free timber

sawn-timbers of mountain larch, selected according to eight quality criteria, core-free thus decreasing the occurrence of cracking



anchoring to the ground

all parts used for anchoring to the ground made of hot-dip galvanised steel



Dimensions

(small deviations possible)

height	1.50 m
length	3.20 m
width	1.00 m
weight	200 kg

Safety

This equipment is not playground equipment within the scope of EN 1176 and therefore is also not subject to the requirements of this standard. Nevertheless, it is complied with where appropriate.

For more detailed explanation of the quality characteristics see price list.

Components

- 1 piece of equipment
- 4 steel feet

Installation information

Surfacing corresponding to a fall height of ≤ 0.60 m recommended: wood chips, granular material or the like

Foundations
4 items 40 x 40 x 35 cm
excavation depth 55 cm

Attention!
Exact measurements may vary, for all installation dimensions refer to current installation instructions.
Subject to technical changes!

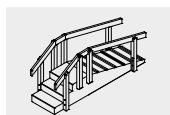

Effect

Stamina and agility are promoted. Everyday challenges can be practiced in the form of various exercises. Safety in daily life is thereby improved and mobility increased.

Purpose

Everyday life can contain various hazards. Climbing stairs, descending stairs, stepping over obstacles, racing from one place to another. For a child a step can be an obstacle which is almost impossible to overcome. For older people an uneven path can pose a dangerous challenge. Those who are prepared for these hazards can master everyday life with happiness and safety. Specifically designed exercises promote mobility and make independent living easier.

Function

The stations, based on real-life situations, invite you to try them out and exercise. Alongside agility, stamina is also trained in this circuit course. The path is set up so that not all the obstacles need to be overcome and so that an accompanying person can give best possible help. Handrails on both sides at every station additionally ensure the highest safety.

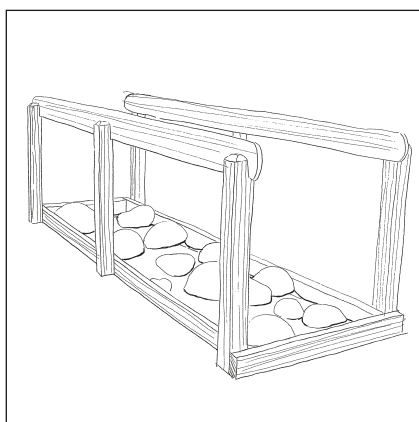

11.50402 Stone Path

Life Path
Stone Path
Wooden Path with log end pavers

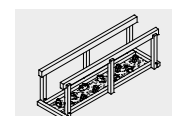

11.50402

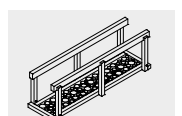

11.50403

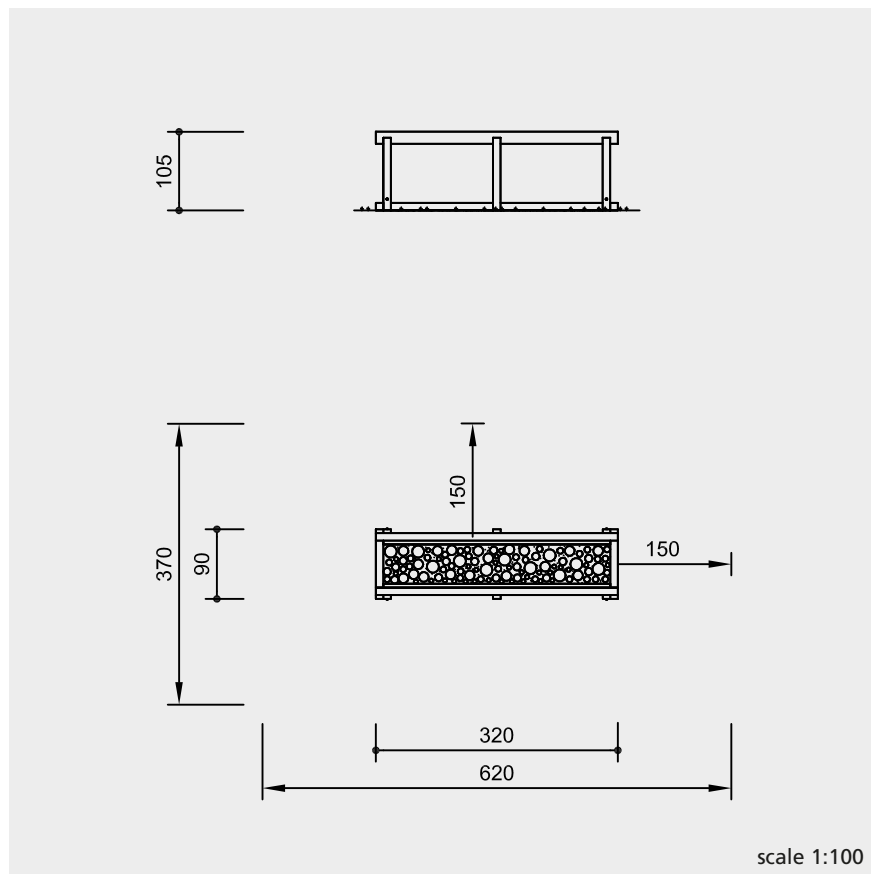

Technical information

Core-free timber

sawn-timbers of mountain larch, selected according to eight quality criteria, core-free thus decreasing the occurrence of cracking



anchoring to the ground

all parts used for anchoring to the ground made of hot-dip galvanised steel



Dimensions

(small deviations possible)

height	1.05 m
length	3.20 m
width	0.90 m
Order No. 11.50402	495 kg
Order No. 11.50403	335 kg

Safety

This equipment is not playground equipment within the scope of EN 1176 and therefore is also not subject to the requirements of this standard. Nevertheless, it is complied with where appropriate.

For more detailed explanation of the quality characteristics see price list.

Components

Order No. 11.50402 Stone Path

- 1 frame
- 1 pallet of stones
(to be filled with e.g. sand on site)
- 4 steel feet

Order No. 11.50403 Wooden Path with log end pavers

- 1 piece of equipment with pre-mounted log end pavers
(to be filled with e.g. sand on site)
- 4 steel feet

Installation information

Surfacing
no requirements
recommended:
bark mulch, wood chips, or the like

Foundations
4 items 30 x 30 x 35 cm
excavation depth 55 cm

Attention!
Exact measurements may vary, for all installation dimensions refer to current installation instructions.
Subject to technical changes!

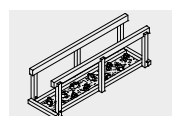

11.50402

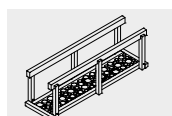

11.50403

Effect

Stamina and agility are promoted. Everyday challenges can be practiced in the form of various exercises. Safety in daily life is thereby improved and mobility increased.

Purpose

Everyday life can contain various hazards. Climbing stairs, descending stairs, stepping over obstacles, racing from one place to another. For a child a step can be an obstacle which is almost impossible to overcome. For older people an uneven path can pose a dangerous challenge.



Those who are prepared for these hazards can master everyday life with happiness and safety. Specifically designed exercises promote mobility and make independent living easier.

Function

The stations, based on real-life situations, invite you to try them out and exercise. Alongside agility, stamina is also trained in this circuit course. The path is set up so that not all the obstacles need to be overcome and so that an accompanying person can give best possible help. Handrails on both sides at every station additionally ensure the highest safety.

Life Path
Wooden Path with round logs

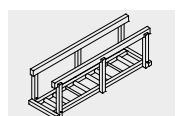

11.50404

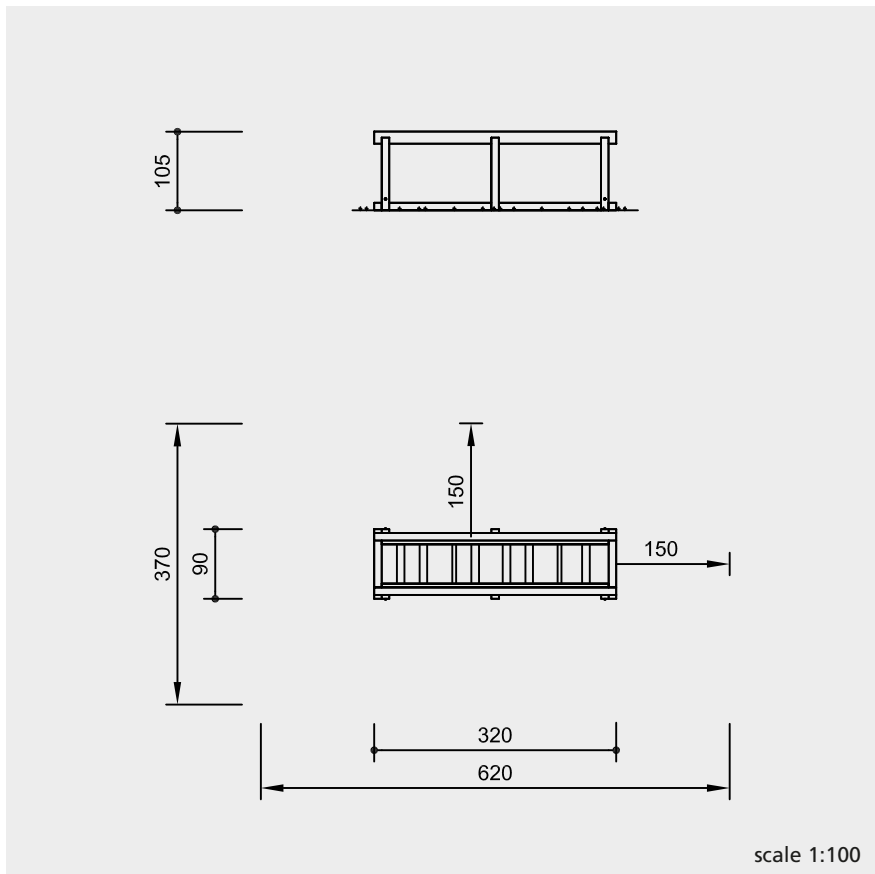

Technical information

Core-free timber

sawn-timbers of mountain larch, selected according to eight quality criteria, core-free thus decreasing the occurrence of cracking



anchoring to the ground

all parts used for anchoring to the ground made of hot-dip galvanised steel



Dimensions

(small deviations possible)

height	1.05 m
length	3.20 m
width	0.90 m
weight	210 kg

Safety

This equipment is not playground equipment within the scope of EN 1176 and therefore is also not subject to the requirements of this standard. Nevertheless, it is complied with where appropriate.

For more detailed explanation of the quality characteristics see price list.

Components

- 1 piece of equipment with permanently attached round logs (to be filled with e.g. wood chips on site)
- 4 steel feet

Installation information

- Surfacing
 - no requirements
 - recommended: wood chips, granular material or the like
- Foundations
 - 4 items 30 x 30 x 35 cm
 - excavation depth 50 cm

Attention!
Exact measurements may vary, for all installation dimensions refer to current installation instructions.
 Subject to technical changes!

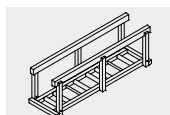

11.50404

Effect

Promoting stamina and agility. Everyday challenges can be practiced in the form of various exercises. Safety in daily life is thereby improved and mobility increased.

Purpose

Everyday life can contain various hazards. Climbing stairs, descending stairs, stepping over obstacles, racing from one place to another. For a child a step can be an obstacle which is almost impossible to overcome. For a senior citizen an uneven path can pose a dangerous challenge.



Those who are prepared for these hazards can master everyday life with happiness and security. Specifically designed exercises promote mobility and make independent living easier.

Function

The stations, based on real-life situations, invite you to try them out and exercise. Alongside agility, stamina is also trained in this circuit course. The path is set up so that not all the obstacles need to be overcome and so that an accompanying person can give best possible help. Handrails on both sides at every station additionally ensure the highest safety.

Life Path
Wooden Path

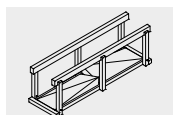

11.50405

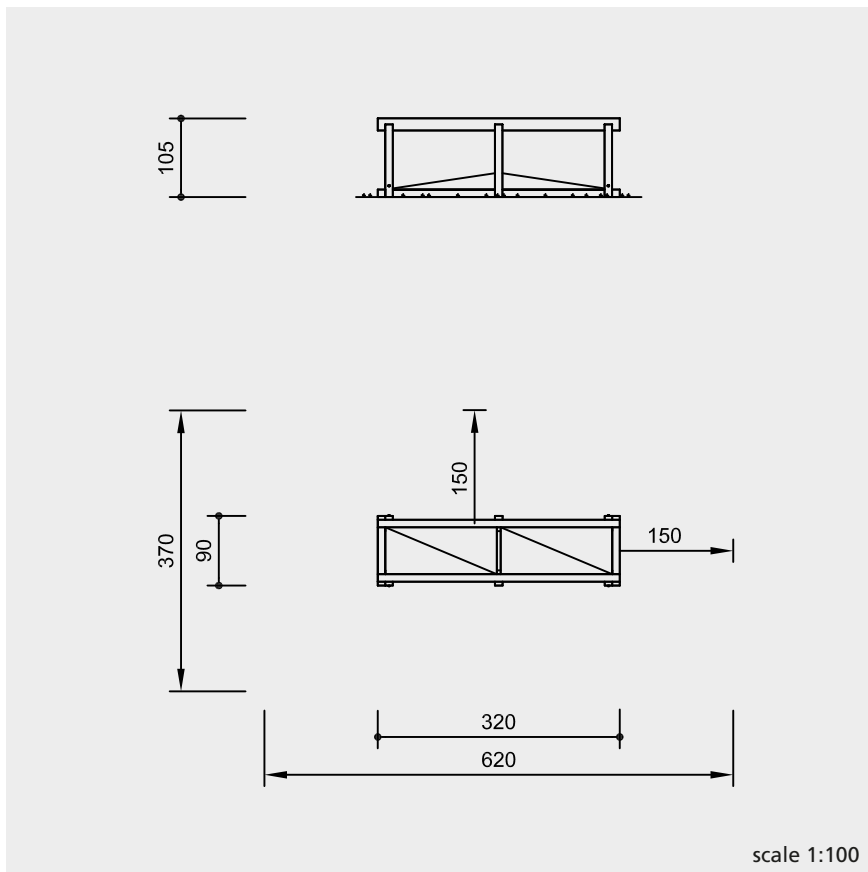

Technical information

Core-free timber

sawn-timbers of mountain larch, selected according to eight quality criteria, core-free thus decreasing the occurrence of cracking



anchoring to the ground

all parts used for anchoring to the ground made of hot-dip galvanised steel



walking board made of waterproof plywood 27 mm, with anti-slip coating

Dimensions

(small deviations possible)

height	1.05 m
length	3.20 m
width	0.90 m
weight	120 kg

Safety

This equipment is not playground equipment within the scope of EN 1176 and therefore is also not subject to the requirements of this standard. Nevertheless, it is complied with where appropriate.

For more detailed explanation of the quality characteristics see price list.

Components

- 1 piece of equipment completely pre-assembled
- 4 steel feet

Installation information

Surfacing
no requirements
recommended:
wood chips, granular material or the like

Foundations
4 items 40 x 40 x 35 cm
excavation depth 55 cm

Attention!
Exact measurements may vary, for all installation dimensions refer to current installation instructions.
Subject to technical changes!

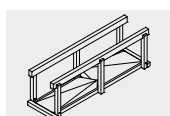

11.50405

The Mature Person and the Eternal Child

Wolfram Graubner

Why are we making equipment for older people to develop the senses, aid perception and facilitate playful contact with the phenomena of our world?

I am neither a play theorist nor a physiologist – that's why the following does not claim to have universal validity, it promises no results. I simply had the luck to meet people like Wladimir Lindenberg, Hugo Kükelhaus and Karlfried Graf Dürckheim. Not only did friendship connect us, but also an intensive work collaboration up to a very old age with the latter two.

My introduction here is a very personal response to this.

I'd like to begin with a small anecdote about Hugo Kükelhaus that touched my heart. He told me that as a child he used to have fun bending over and observing the "world" through his legs. Colours appeared to be more intensive and brighter this way.



Standing on your head the world is a much brighter and more exciting place. When you're next somewhere really beautiful – by the sea, in the mountains, maybe in the woods – why not bend down and take a look at it all upside down?

I return to my initial question: Why do we want to offer older people the equipment which will allow them to have these experiences, equipment with which you can make and observe rainbows and ones where you can make stones sing or vibrate yourself?

Actually I should phrase that question differently because, basically, I do not work for the old or the young, the mature or the immature person. By this, I mean that I actually do not work with a particular age group or mental state in

mind. I never reject a beautiful phenomenon because it appears not to be suitable for a particular age group or for people with certain limitations who could not reach it without help.

How wonderful it is to help each other! I don't construct something due to a desire to return to what I once took pleasure in doing.

Actually I like to play here and now. This is, however, often seen as wrong – after all what purpose does it serve and, not least of all, the equipment costs money.

Up to now I have resisted defining a recipe for well-being. I also can no longer play in a carefree way if this is demanded of me. That demystifies the magical process of playing.



In most people there still resides a germ of the instinct to play. Even the most important discoveries of science – according to the statement of the discoverers – often go back to a playful handling of these appearances of reality.

Also artists and philosophers live with a child's "godly play" within them. This child is independent of its external age and allows us the internal flexibility to continually transform ourselves when our life paths requires us to.

Within us, there where only the perception of the soul reaches, we hold a picture of what we could be. As long as we do not achieve this then we remain unsatisfied. Up to the very last day we should keep on further developing. Often, however, we are blind and dumb towards this creative strength that lies within us.

Our eye and ear games and our play stations are made for the inner child who lives in me and in everyone. The equipment doesn't need to be handled in a particular way or require any previous knowledge. It is not about testing knowledge and not about testing skills. The visitor does not have to reach a certain level and there is no learning target.

It is a moving experience to meet people who can raise above themselves – who not only notice everyday objects but can view them at leisure and wonder at them, maybe even love them.

A Japanese Zen master once said:

"Have you noticed how the pebbles on the street look so clean and shiny after the rain? Pure artistry! And these flowers. There are no words to describe them. You can only let out a cry of wonderment "Ah". You have to be able to understand the "Ah!" in things". And Lindenberg adds: "Which of us still understands the "Ah" in things? The child who cries "Ah" whenever it sees any new object and wonders and marvels at it. How wonderful and magical is this childhood amazement! Are we already too old to marvel? Is there nothing in this wide world that we can marvel at?"

And Kükelhaus explains:

*Hast Du mal
gesehen, wie sich
in einem Taupfropfen die
ganze Welt spiegelt?
Oben die Erde,
unten der Himmel.
Das Auge ist wie solch ein
Taupfropfen. Die ganze Welt
beschaunt sich in ihm.
Und nur darum kann
es sehen.*

Have you ever noticed how the whole world is reflected in a drop of dew? With the earth at the top and the sky down below. The eye is just like a dewdrop. The whole world is displayed inside it. And this alone enables it to see.

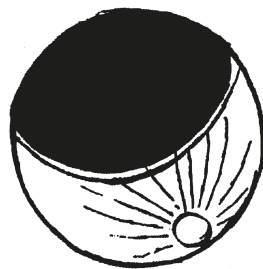

The painter learns that kind of wonder; they see the symbolic in the object so that this phenomenon becomes the most important thing. Such wondrous observing, such attention is an art, and requires time, which we much too often don't take. Such observation makes the mature person kind and open, aware and loving.

"The work of a practiced artist or a craftsman is a sign of real maturity, it appears as though each movement, each touch is carried out playfully and with the greatest of ease and yet we know how much effort is required to learn this craft." (Wladimir Lindenberg)

Concern for the aged, the sick and the weak is rewarding positively if we take the time because a life lived in thoughtfulness is healing. In this way old people, children and people with disabilities can become the teachers in a society where many people no longer reach maturity. Herein lays the importance of including these people in our society. The meaningful, thoughtful and perceptive play cannot be categorized as useful. Whether these games therapeutically improve the sense of sight, the hearing, the deep sensitivity of the hand etc, seems obvious but has not been proven.



During the maturing process the eyes and ears open less to the superficial than to what can be recognised in the background. It is only through this that life gains meaning. "I loved you late, you beauty, so ancient and so new, I loved you only late. And see you were always inside me and I was outside and looked for you there!" (Augustinus)

I don't want to say that I regard all the equipment, which has been designed to keep the older generation fit, as unnecessary but I am against the one-sidedness which sucks the life out of the people.

In Asian culture there is a tradition of „do“, which means the exercise path to enlightenment, whereby the physical exercises serve to raise the awareness of the soul. `Tai Chi`, `Aikido` or `Jaido` support people on this path to maturity. There is no need for older people to be ashamed of carrying out these physical exercises because here it is the elders who are the masters.

The type of fitness equipment which we do today is connected to this old tradition.

"Happiness does not ask why – it is born of nothing, it is a pure state of the soul." (Lindenberg)

For me, this enjoyment in free, self-determined and unintentional play is the motivation for developing the play stations and meeting and observing wonderful phenomenon together. Is that a luxury of the soul or is it of the utmost necessity? Isn't it now in this day and age where we are showered with unreal, media dumbing of the senses where it is vital that we once again take our strength from what is real? After all, where should our aged people find the strength for their final path. From a culture of diversion, consumerism and distraction or from connecting with reality which is found in thoughtfulness and openness and which will help them to let go?



10.11000 Impulse Spheres

Create a variety of rhythms in the simplest way, thereby using hearing and seeing. If the first sphere or also several spheres are pulled back and released to collide with the others, something truly amazing can be experienced: the impulse travels unseen through the whole row of spheres and only becomes perceptible at the last sphere. Figuratively, in the same way an impulse in one person is transferred and perceived in another.

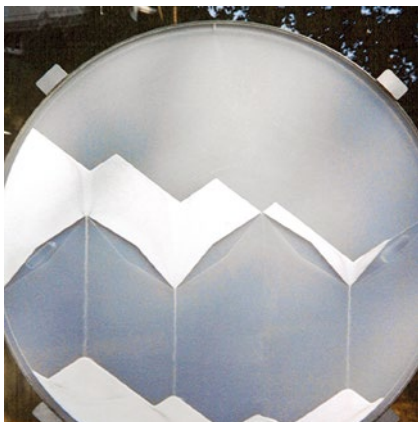

10.13100 Turning circle

Just a gentle turn of the disc is enough to change the picture into ever new and flowing forms, each unique and fleeting. Whole landscapes and aesthetic patterns appear in the sand. Turning the disc too fast results in chaos. However, if the disc is left to trickle while stationary, new structures form. This law of nature can also be applied to people and to the continual changes during a human life.



10.15000 Pattern Board

In the space between two sides of a transparent board is water. Minute particles form different shapes. The board can easily be set into gentle pendulum movement. The influence of rhythm creates designs. Water currents which run into one side form waves whose structure is reminiscent of sand on the sea bottom. It becomes clear how water washes around obstacles and flows through narrow channels. Along obstacles, typical patterns form in the congestion in front and the suction behind.

This game transforms itself into a physical experience for people.

10.17000 Water Column

Screw-like and spiralling movements naturally occur in nature. The water column is driven by a crank. The function of a crank has a very stimulating character also for people with dementia. While watching the whirlpool movement, fine muscle reflexes are triggered, so-called deliberate intended movements. That stimulates the fine motor skills. Whirlpool movements can be traced back to the beginning of our development; this perception opens the internal to the external and the external to the internal.



10.19200 Double Helix

Optical game: By turning the Double Helix, the outer and the inner spiral, which are connected to each other, move in such a way that we perceive it as an upward and downward movement. As with the pendulum, but here in a circulating movement, we experience the universal principle that in every rise a fall is inherent and vice versa. Optical games such as these are especially beneficial to people with reduced mobility because the observation triggers the finest of movements.



10.22100-10.22850 Rotating Discs

The observer gently spins the disc and then takes a step back. Looking at the disc the eye actively and automatically creates complementary and polar counter images. This creates surprising, colourful light phenomena. Turning the disc slowly creates the impression of a rotating cone and funnel. The brain is thereby stimulated into actively constructing a perspective image. The pattern becomes a funnel or a trunk.



10.23100 Kaleidoscope - 10.24100 Octascope

Originally in Greek, kaleidoscope meant "beautiful picture viewer". This perception awakens the power of imagination not just for children.

The view through the Octascope focuses on the world. As with the Kaleidoscope, the reflection causes a symmetry thus creating new shapes and arrangements by the turning of mirrors when the Octascope is manipulated.





10.31000 Water Prism

If you look through the prism in daylight, the most wonderful colours can be seen: red, orange, yellow, green, light blue, dark blue and purple. Smaller dark objects in the surrounding area appear to be totally colourful, lines look as if they are curved, and, in the boundary between sunlit and shadowed areas, coloured fringes appear. This is all about the relationship of people to colours, on the perception of colour.



10.31100 Glas Prism

The glass prism works the same way as the water prism, but is smaller and shaped differently.



10.41100 Small Singing Stone

If you place your head in the stone's hollow and hum different notes, it is possible to find the note at which resonance occurs. It is possible thereby to feel the vibration of your own voice throughout the whole body, sooth painful spots and immerse yourself.



10.42000 Large Singing Stone

If you hum in the Large Singing Stone you are transported into another world. The organic and striking six to eight sided column shape is like a natural monument, something which is nowadays difficult to find and this is what makes this so special.

10.44000 Tuning Stone

Sounds create different moods. Not enough auditory input makes you lonely. Vibrations can be created by rubbing the stone carefully but firmly with a little water. The sound is experienced through the skin and hands. If you place your hands on the tabletop then, at first you only feel coldness and hardness. However, soon you begin to feel a curious prickling in your fingers followed by various small movements of the hands. A whole new life appears, first in the fingertips, then in the fingers, then the whole hand. In the realm of tactile qualities the hand starts to blossom. This is often a special experience for older people because there is frequently a decline in the movement and depth of sensitivity in the hands.



10.45000 Stone Harp

With this stone you can create wonderful tones which resemble the heavenly sounds of a harp.



10.46000 Stone Xylophone

Stones are not mute. Being able to generate a sound from the oversized stones of the giant xylophone is a moving experience. If desired the stone can also be positioned at table height.



10.52000 Triangles

A tone is not just a noise but a sound which the ear perceives as pure and of constant pitch. Many adults have memories of triangles from their childhood.





10.52160/10.52180 Gong

The skin can also perceive sound. Sound waves, especially those from gongs, are not only perceived by the ear but also by the skin. The vibrations emitted by the gong are perceived as relaxing and invigorating on the skin and pass right through all the different areas of the body. That is why the gong is also used for therapy. The mode of action is related to acupuncture.



10.52200 Metal Gongs

The force and rhythm with which the Metal Gongs are struck gives rise to different sounds and resonances. Each metal disc produces a particular range of sound. There are calming sounds which find resonance in particular areas of the body, head, neck, chest or stomach, depending on pitch. Several people can play simultaneously and create music by listening to each other.



10.52400 Tubular Chimes

Tubular Chimes are, like other orchestral instruments, tuned precisely. No other instrument can produce such a clear and lasting sound.

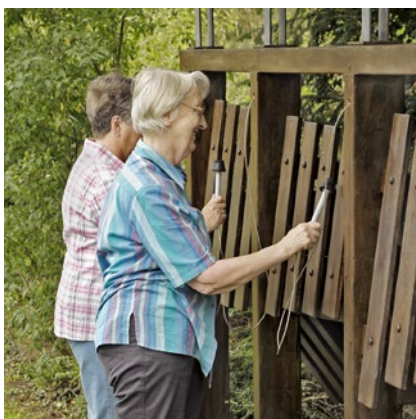

10.53000 Dendrophone

The Dendrophone is a simple to use musical instrument. The individual notes are easy to hit. Memories of melodies can be evoked here and helpers can supplement the sequences of notes, conversations can be sparked. Wood sounds are pleasant. Several people can play simultaneously and create music by listening to each other.

10.53100 Tubular Dendrophone

The Tubular Dendrophone is quieter than the normal Dendrophone. By placing your hand on a ringing tube you can experience the wood's vibration.



10.53200 Sound Arch

The Sound Arch which consists of 5 wooden sound tubes can be played from both sides at the same time. This has the effect of particularly encouraging the participants to play together and listen to each other. The warm tones of the wooden tubes could be described as "stomach sounds".



10.55000 Conference

Just like an old ship's telephone you can communicate through underground tubes. That encourages contact. It is possible to communicate over unusually long distances without the use of any electronic amplifiers. However, visual contact makes sense.



10.55100 Echo Game

You call and the world answers you, you clap and space reacts. If you don't receive an answer, which so many hard of hearing people experience, this can be an oppressive feeling. With the echo game you can amplify the echo.





10.57100 Listening to Water

With this installation visitors are introduced to the natural sounds coming from a watercourse. At first only incidentally, this station arouses curiosity and attention. You can hear dripping, a murmuring, a gurgling or whatever other various water noises there are.



10.58000/10.58100 Melodic Fence

Every culture has its melodies which stay alive by frequent repetition. The Melodic Fence gives you this opportunity to play these melodies as a chorus or as a canon or even backwards if you want to. The fence has been tuned with little familiar melodies such as "Frère Jacques". Other melodies within an octave tone range are possible.



10.61000 Scented Organ

Proverbially speaking, "to have a good nose for it" stands for intuition and memory. The sense of smell is situated in the oldest part of our brains in a developmental sense. That is why suitably chosen scents can awaken memories of situations and open up topics of conversation. However, the scents can also be put together in such a way that two are linked together and can be used as a memory game. The scents can be exchanged. Memories can be beneficial if cognition has diminished and in cases where dementia has become isolating. This can make people apathetic. The veil of apathy can be penetrated by evoking memories.



10.92000 Partner Swing

The life-sustaining bodily process can be recognised by their rhythmical characteristics. Heartbeat, breathing, digestion. We have almost no influence over them by will alone but they can be stimulated by rhythmical body movements. Walking has the best effect. However we have also had good experience for adults with swing movements. There are also supporting special seats for the partner swing. Here big and small people simply have fun cooperating with each other through this interactive game.

We love nature!
FSC-certified GardaPat 13 Kiara paper was used
for this catalogue.

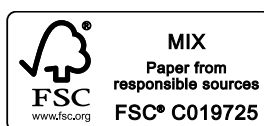



①

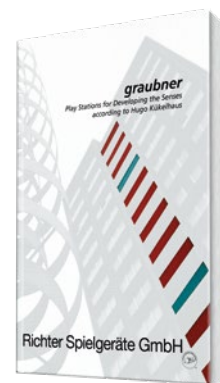

⑤



②

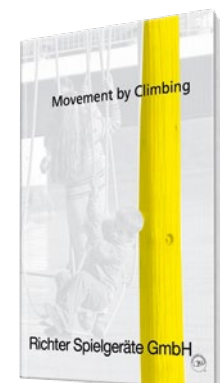

⑥

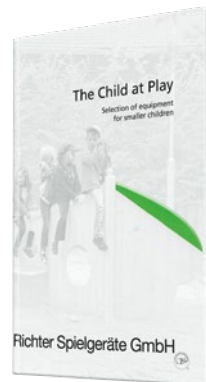

③



④

Do you want to know more about us?

The main catalogue comprises our complete range of standard equipment.

A selection of our products is described in the following theme catalogues:

- ① Acoustic and Play
- ② Water and Play
- ③ Child and Play
- ④ For the Very Young
- ⑤ graubner Play Stations for Developing the Senses
- ⑥ Movement by Climbing

Water and Play and Child and Play only available in German language.

Please ask for our information materials.
We look forward to hearing from you.
Phone +49-80 52-1 79 80

